

General characteristics

	210/215	410/415	610/615
No. of poles	2 Form C (2 DPDT)	4 Form C (4PDT)	6 Form C (6PDT)
Volume	3.3 cm ³ [.52 in ³]	3.3 cm ³ [1.03 in ³]	3.3 cm ³ [1.53 in ³]
Mass	46 grams [.10 lb. Max]	77 grams [.17 lb. Max]	118 grams [.26 lb. Max]

Switching characteristics

Operate time @ 25°C with DC COIL with AC Coil	10 ms max. 20 ms max.	15 ms max. 20 ms max.	15 ms max. 20 ms max.
Release time @ 25°C with DC COIL with AC Coil	10 ms max. 50 ms max.	15 ms max. 50 ms max.	15 ms max. 50 ms max.
Bounce time	1 ms max.	1 ms max.	1 ms max.
Mechanical Life	400,000 cycles		

Contact rating	Type of load (High level)	Cycles x 10 ³	28 Vdc	115 Vac			115/200 Vac		10 AMP * = 10,000 CYCLES
				400 Hz 1 phase	115 Vac* 50/60 Hz 1 phase	115/200 Vac 400 Hz 3 phase	115/200 Vac* 50/60 Hz 3 phase		
	Resistive	100	10 amps	10 amps	2.5 amps	10 amps	2.5 amps		
	Inductive	20	8 amps	8 amps	n/a	8 amps	n/a		
	Inductive	10	n/a	n/a	2.5 amps	n/a	2.5 amps		
	Motor	100	4 amps	4 amps	2 amp	4 amps	2 amps		
	Lamp	100	2 amps	2 amps	1 amps	n/a	n/a		
	Overload current	n/a	40 amps	60 amps	n/a	60 amps	n/a		
	Rupture current	n/a	50 amps	80 amps	n/a	80 amps	n/a		

Contact rating	Type of load (High level)	Cycles x 10 ³	28 Vdc	115 Vac		115/200 Vac		15 AMP * = 10,000 CYCLES
				400 Hz 1 phase	115 Vac* 50/60 Hz 1 phase	115/200 Vac 400 Hz 3 phase	115/200 Vac* 50/60 Hz 3 phase	
	Resistive	100	15 amps	15 amps	3.75 amps	15 amps	3.75 amps	
	Inductive	20	10 amps	10 amps	n/a	10 amps	n/a	
	Inductive	10	n/a	n/a	3.75 amps	n/a	3.75 amps	
	Motor	100	6 amps	6 amps	3 amp	6 amps	3 amps	
	Lamp	100	3 amps	3 amps	1.5 amps	n/a	n/a	
	Overload current	n/a	40 amps	60 amps	n/a	60 amps	n/a	
	Rupture current	n/a	50 amps	80 amps	n/a	80 amps	n/a	

Environmental characteristics

Temperature Range	-70°C to +125°C
Vibration, any axis (Sinusoidal) E210/E410 E410 Mounting Style 3 E610	30 g 10-3000 Hz 20 g 57-3000 Hz 20 g 10-2000 Hz
Shock, any axis E410 Mounting Style 3 E610	200 g 6 ms 100 g 6 ms 50 g 6-9 ms
Seal	Hermetic (1 x 10 ⁻⁸ atm cm ³ /s)

Electrical characteristics

Contact voltage drop (@ Rated resistive load)	
- Initial	150 mV Max.
- After guaranteed life	175 mV Max.
Dielectric strength @ sea level	Coil to Case All other points
- Initial @ 60 Hz	1000 Vrms 1250 Vrms
- After guaranteed life	1000 Vrms 1000 Vrms
Insulation Resistance	
- Initial	100 Megohms min. @ 500 Vdc
- After life tests	50 Megohms min. @ 500 Vdc
Reference Military Specifications	MIL-PRF-83536

E S 2 10 E 2 C D

RELAY TYPE

'E' SERIES

OPTIONAL

'S' : with internal voltage suppressor

'A' : AC COIL

MODEL

2: 2 PDT see page 13, 15-19

4: 4 PDT see page 13, 20-25

6: 6 PDT see page 13, 26-29

RELAY AMPS

10: 10 AMPS

15: 15 AMPS

COIL CODE

2: see page 15

4: see page 20

6: see page 25

MOUNTING STYLES

2: see page 16-17

4: see page 21-23

6: see page 26-27

TERMINATION STYLE AND FINISH

2: see page 18-19

4: see page 24-25

6: see page 28

'D' FOR CATALOG STANDARD OR

'A' FOR CATALOG STANDARD WITHOUT ARC BARRIERS

'XXXX' FOR SPECIAL INSTRUCTIONS OR SPECIFICATIONS

(ASSIGNED BY DRI)

Coil characteristics

COIL CODE	DC						AC		
	A	B	D	E	G	J	K	L	N
Nominal coil voltage	6	12	26.5	28	48	110	28-400 Hz	115-400 Hz	115-50/60/400 Hz
Maximum pick-up voltage at 25°C	3.2	6.5	13.5	14	24	55	16.2	73	73
Maximum pick-up voltage at 125°C	4.5	9.0	18	18.7	36	70	22.4	90	90
Maximum hold voltage at 125°C	2.3	4.5	7.0	7.0	14	30	9.0	30	40
Minimum drop-out voltage at -70°C	0.25	0.5	1.2	1.5	2	5	1.0	5	5
Coil resistance (ohms \pm 10% at 25° C)	20	80	320	320	955	5000	-	-	-
Maximum coil transient suppression	42	42	42	42	100	180	-	-	-

OTHER VOLTAGES AVAILABLE FROM FACTORY ON REQUEST

Circuit diagram

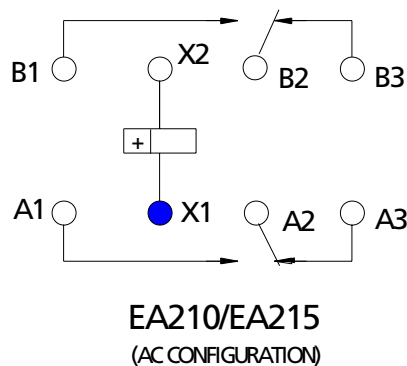
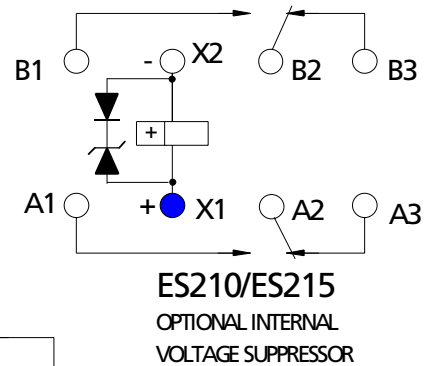
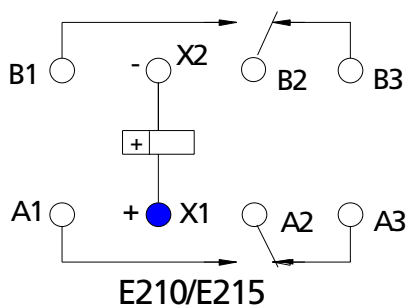

■ Mounting styles

DIMENSIONS ARE IN MM (IN.)
UNLESS OTHERWISE SPECIFIED, TOLERANCE IS $\pm 0,25$ [.010]

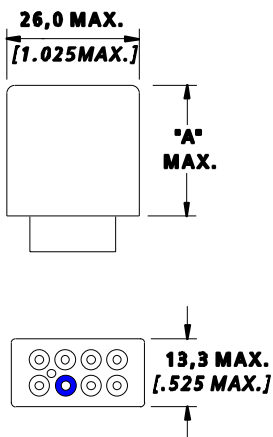

STYLE 1:
NO MOUNT

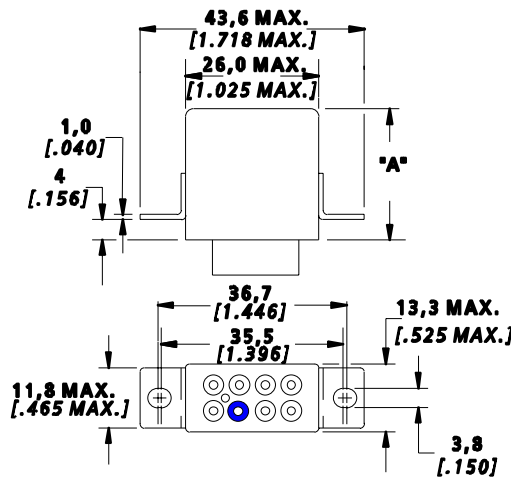

STYLE 2:
RAISED VERTICAL
FLANGE MOUNT

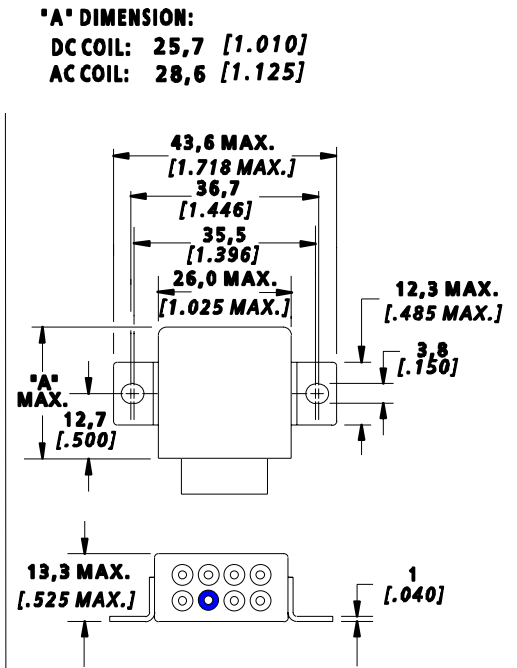

STYLE 3:
HORIZONTAL
FLANGE MOUNT

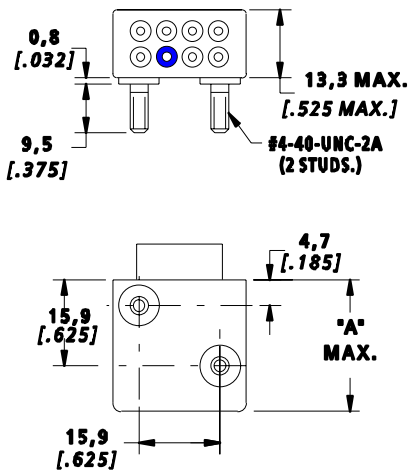

STYLE D:
SIDE STUD

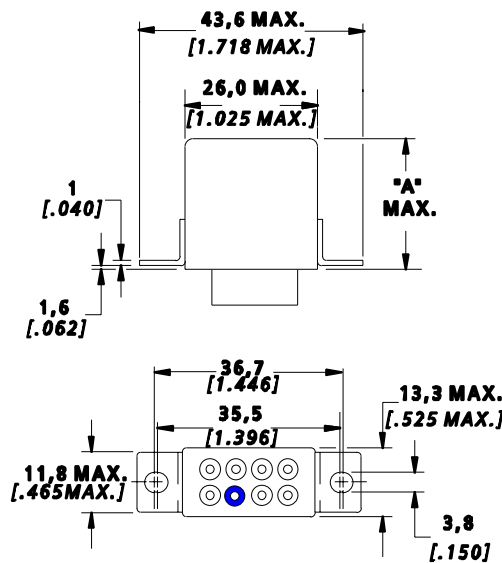

STYLE N:
VERTICAL FLANGE

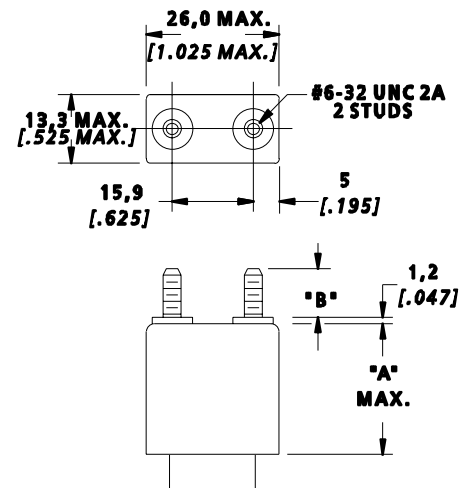

TOP STUD MOUNT

STYLE	DIM "B"
M	9,5 [.375]
R	6,35 [.250]

Mounting styles (cont.)

DIMENSIONS ARE IN MM (IN.)
UNLESS OTHERWISE SPECIFIED, TOLERANCE IS $\pm 0,25$ [.010]

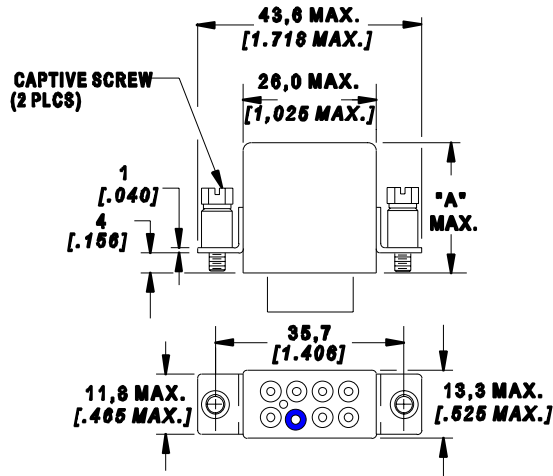

STYLE 8: M3 CAPTIVE SCREWS
STYLE C: #4-40 UNC CAPTIVE SCREWS
RAISED VERTICAL FLANGE MOUNT
WITH CAPTIVE HARDWARE

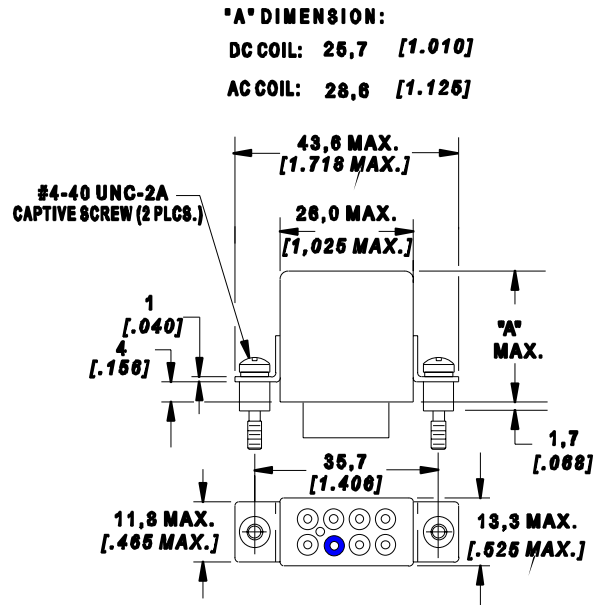

STYLE G:
RAISED VERTICAL FLANGE MOUNT
WITH CAPTIVE HARDWARE

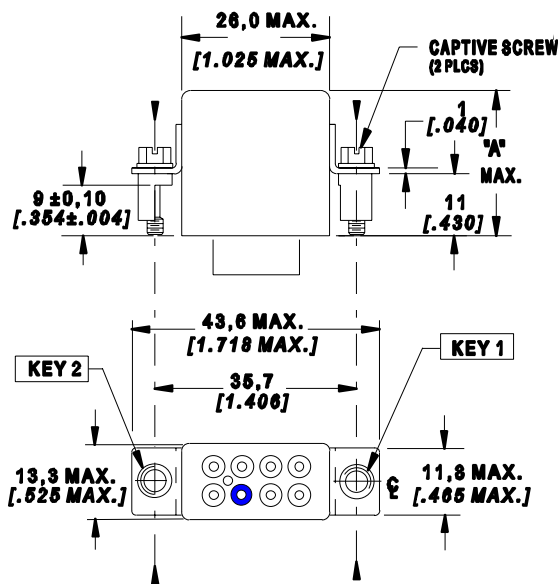

KEYING SYSTEM
WITH CAPTIVE HARDWARE

STYLE A: M3 CAPTIVE SCREWS
STYLE B: #4-40 UNC CAPTIVE SCREWS

'A' DIMENSION:

DC COIL: 25,7 [1.010]

AC COIL: 28,6 [1.125]

KEYING POSITIONS

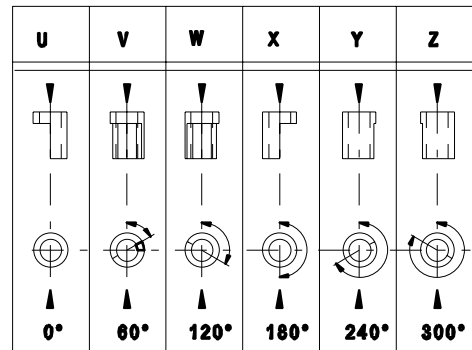

COIL	SUPPRESSED			
	KEY 1	KEY 2	KEY 1	KEY 2
6 VDC	V	V	V	X
12 VDC	X	V	X	X
26.5 VDC	X	Y	V	Z
28 VDC	X	Z	Y	Y
48 VDC	V	U	V	W
110 VDC	X	U	X	W
115 VAC	U	V		

KEYING CONFIGURATION SHOWN IN TABLE COMES STANDARD WITH SPECIFIED COIL VOLTAGE. FOR ORDERING OTHER KEYING POSITIONS USE 2 DIGIT (XX) 'SPECIAL INSTRUCTIONS' ON END OF P/N.
EX: E210AAC_{YY}

Termination Styles

DIMENSIONS ARE IN MM (IN.)
UNLESS OTHERWISE SPECIFIED, TOLERANCE IS $\pm 0,25$ [.010]

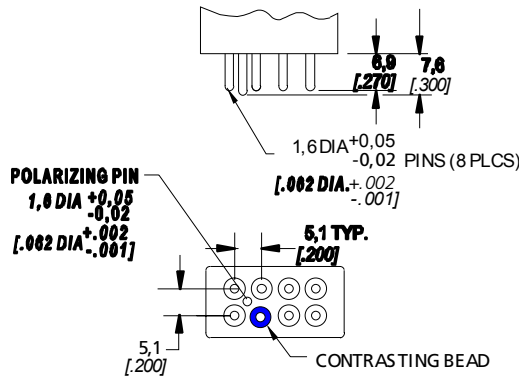

SOLDER PIN

STYLE A: TIN PLATED
STYLE B: SOLDER DIPPED

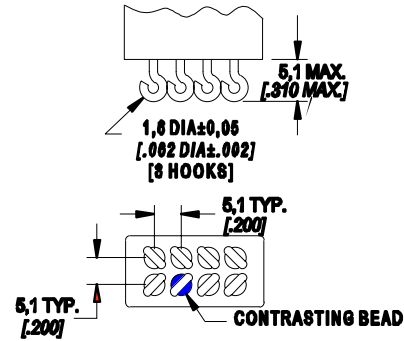

SOLDER HOOK

STYLE H: TIN PLATED
STYLE J: SOLDER DIPPED

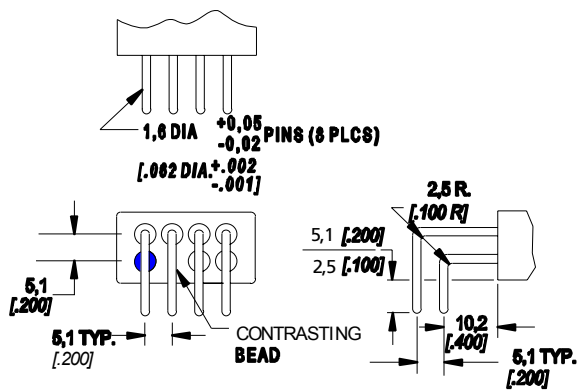

90° SOLDER PIN

STYLE D: TIN PLATED
STYLE E: SOLDER DIPPED

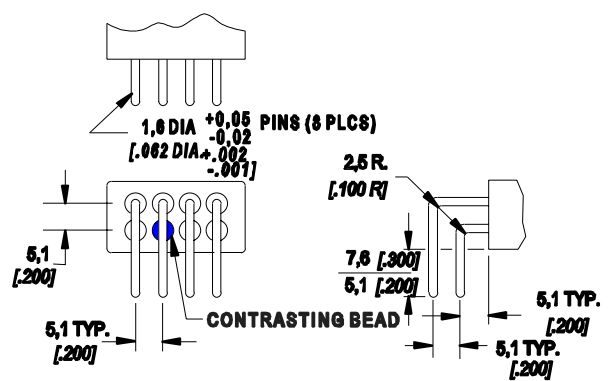

90° SOLDER PIN

STYLE Q: TIN PLATED
STYLE R: SOLDER DIPPED

Termination Styles

DIMENSIONS ARE IN MM (IN.)
UNLESS OTHERWISE SPECIFIED, TOLERANCE IS $\pm 0,25$ [.010]

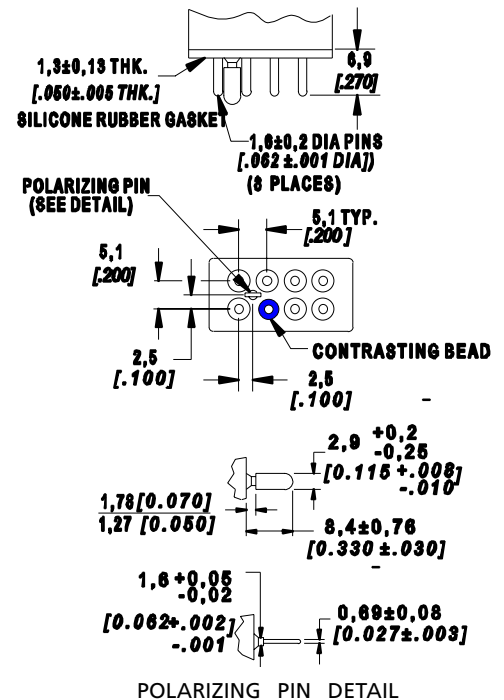
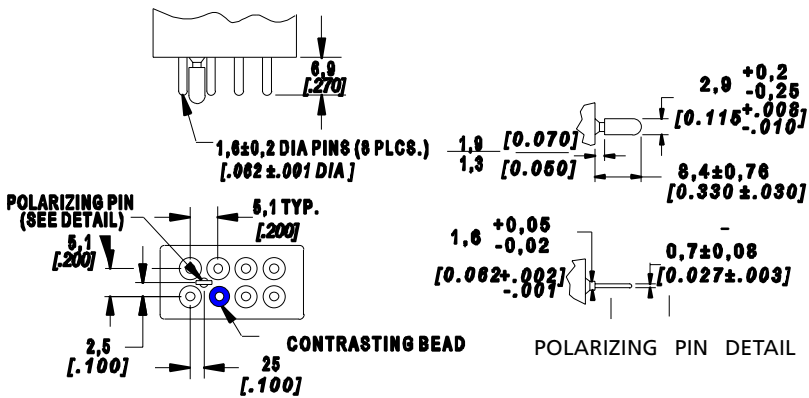
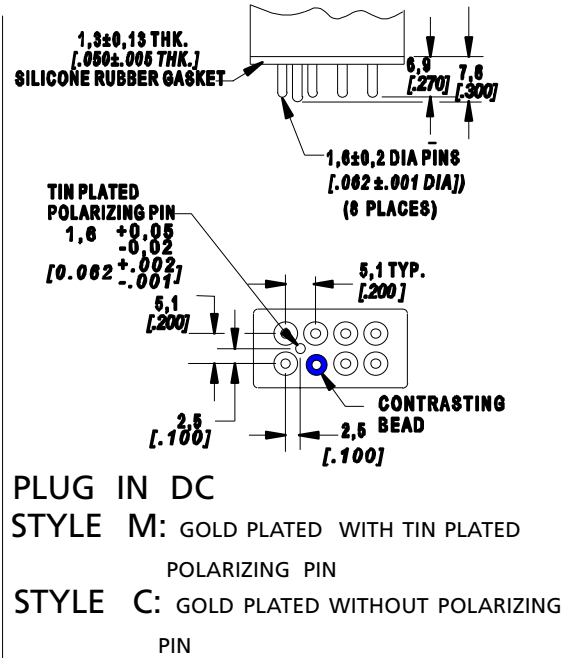
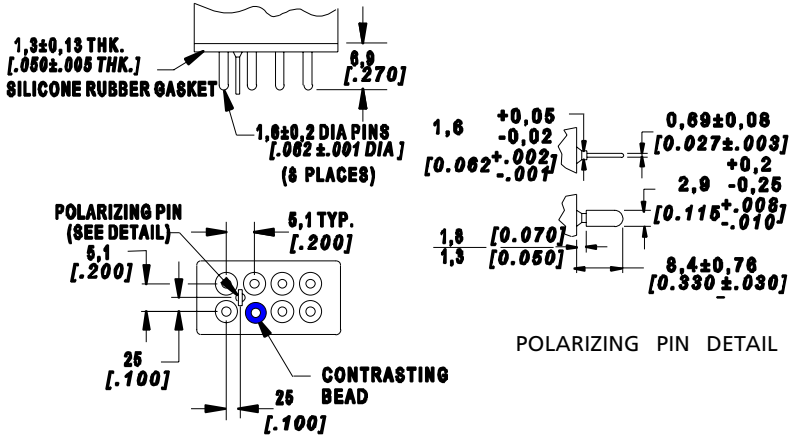

Coil Characteristics

COIL CODE	DC						AC		
	A	B	D	E	G	J	K	L	N
Nominal coil voltage	6	12	26.5	28	48	110	28-400 Hz	115-400 Hz	115-50/60/400 Hz
Maximum pick-up voltage at 25°C	3.2	6.5	13.5	14	24	55	16.2	73	73
Maximum pick-up voltage at 125°C	4.5	9.0	18.7	19.5	36	70	22.4	90	90
Minimum drop-out voltage at -70° C	0.25	0.5	1.5	1.5	2	5	1.0	5	5
Maximum hold voltage at 125°C	2.3	4.5	7.0	7.0	14	30	9.0	30	40
Coil resistance (ohms ± 10% at 25° C)	18	70	290	290	955	5000	-	-	-
Maximum coil transient suppression	42	42	42	42	100	180	-	-	-

OTHER VOLTAGES AVAILABLE FROM FACTORY ON REQUEST

Circuit Diagram

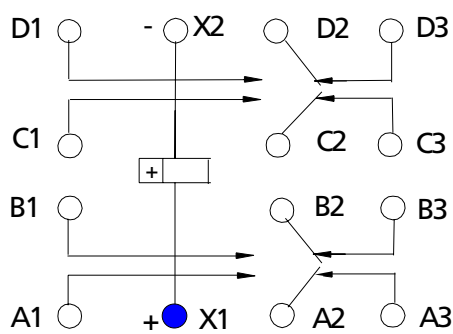

E410/E415

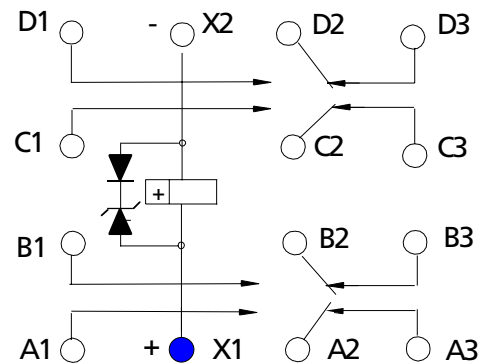

ES410/ES415
OPTIONAL INTERNAL
VOLTAGE SUPPRESSOR

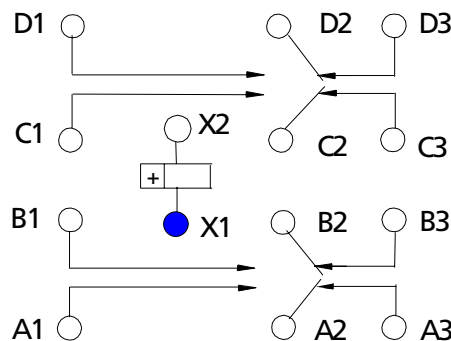

EA410/EA415
(AC CONFIGURATION)

■ Mounting styles

DIMENSIONS ARE IN MM (IN.)
UNLESS OTHERWISE SPECIFIED, TOLERANCE IS $\pm 0,25$ [.010]

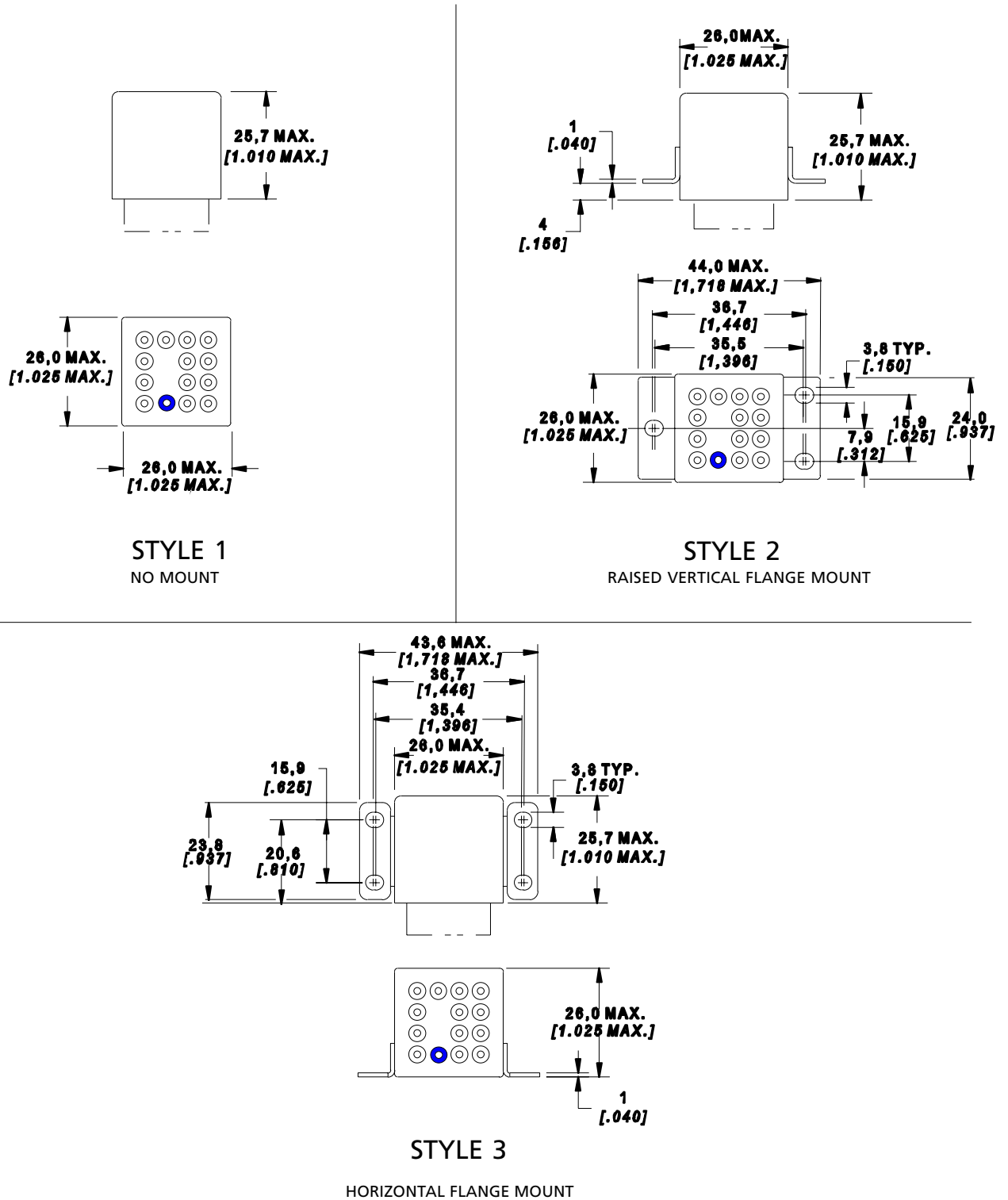

■ Mounting styles [cont'd.]

DIMENSIONS IN MM (IN.)
UNLESS OTHERWISE SPECIFIED, TOLERANCE IS $\pm 0,25$ [.010]

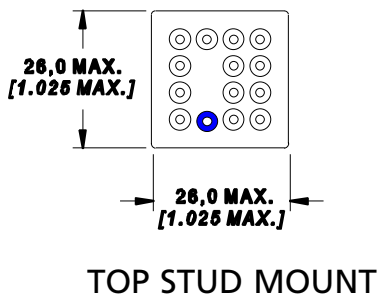
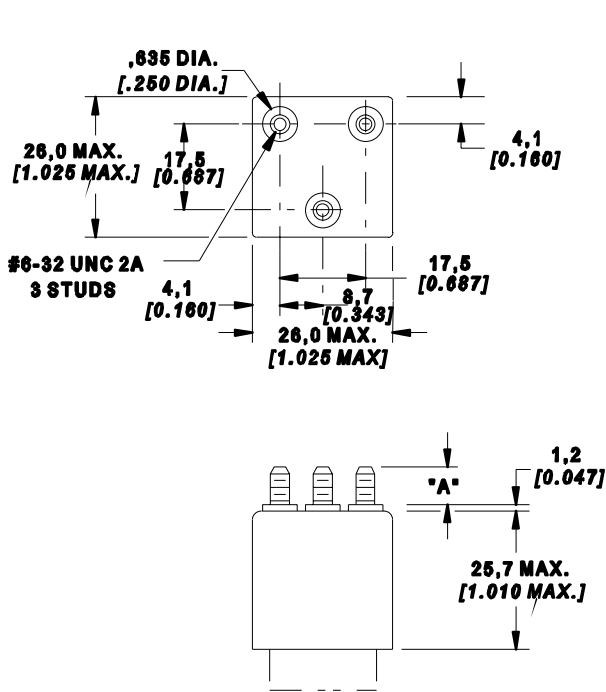

STYLE DIM "A"	
O	9,5 [.375]
R	6,35 [.250]

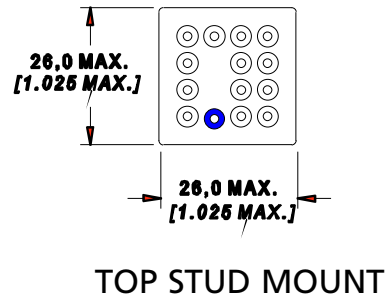
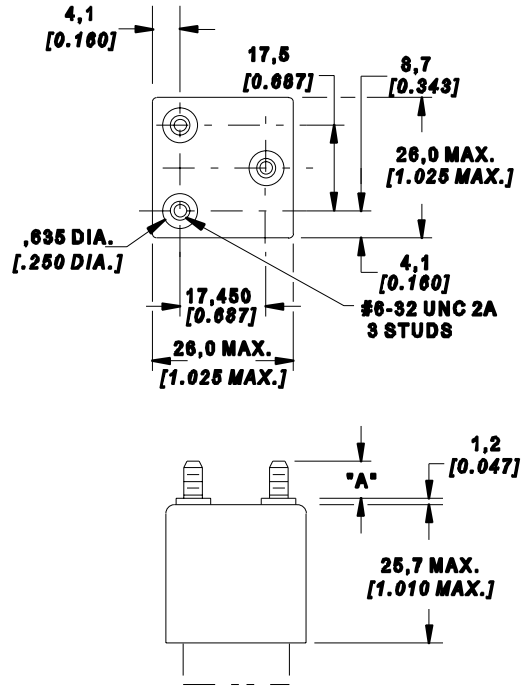

STYLE DIM "A"	
T	9,5 [.375]
U	6,35 [.250]

■ Mounting styles [cont.]

DIMENSIONS ARE IN MM (IN.)
UNLESS OTHERWISE SPECIFIED, TOLERANCE IS ±0,25 [.010]

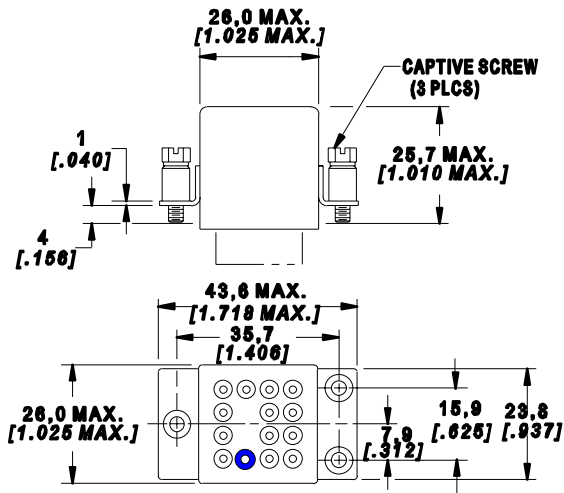

STYLE 8: M3 CAPTIVE SCREWS
STYLE C: #4-40 UNC CAPTIVE SCREWS
RAISED VERTICAL FLANGE
MOUNT
WITH CAPTIVE HARDWARE

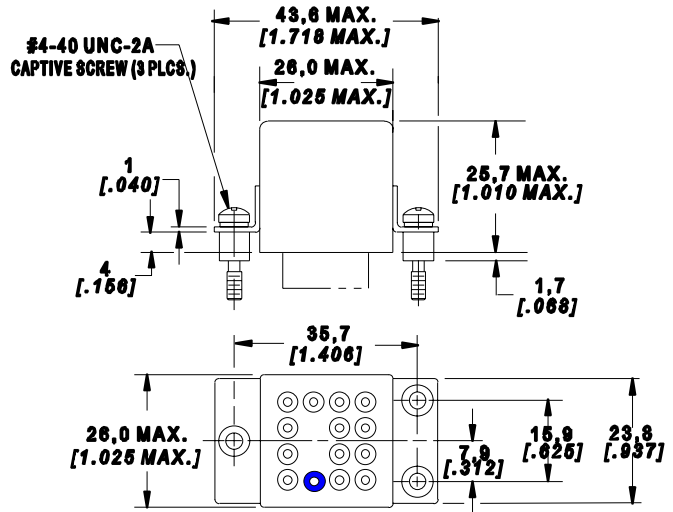

STYLE G:
RAISED VERTICAL FLANGE
MOUNT
WITH CAPTIVE HARDWARE

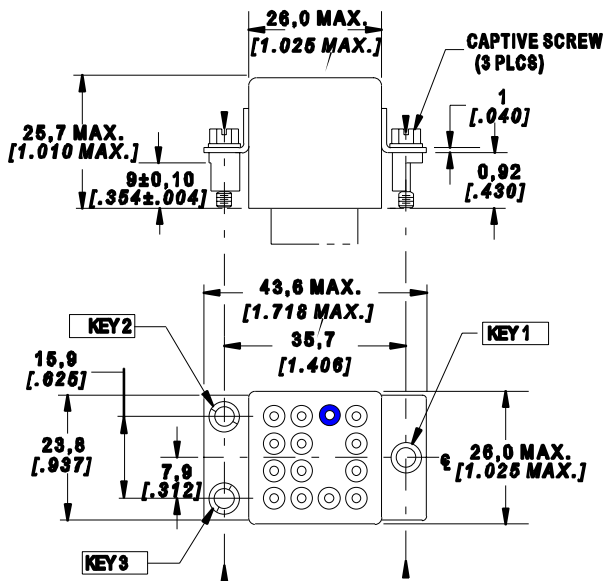

KEYING SYSTEM
WITH CAPTIVE HARDWARE

STYLE A: M3 CAPTIVE SCREWS
STYLE B: #4-40 UNC CAPTIVE SCREWS

KEYING POSITIONS

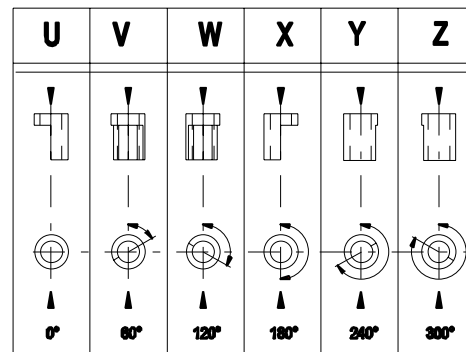

COIL	SUPPRESSED					
	KEY 1	KEY 2	KEY 3	KEY 1	KEY 2	KEY 3
6 VDC	V	Z	V	V	Z	X
12VDC	X	Z	V	X	Z	X
26.5 VDC	X	W	Z	X	W	U
28 VDC	X	W	V	X	W	X
48 VDC	V	Z	U	V	Z	W
110 VDC	X	Z	U	X	Z	W
115 VAC	U	Z	V			

KEYING CONFIGURATION SHOWN IN TABLE COMES STANDARD WITH SPECIFIED COIL VOLTAGE. FOR ORDERING OTHER KEYING POSITIONS USE 3 DIGIT (XXX) 'SPECIAL INSTRUCTIONS' ON END OF P/N.
EX: E410AACXYZ

Termination styles

DIMENSIONS ARE IN MM (IN.)
UNLESS OTHERWISE SPECIFIED, TOLERANCE IS $\pm 0,25$ [.010]

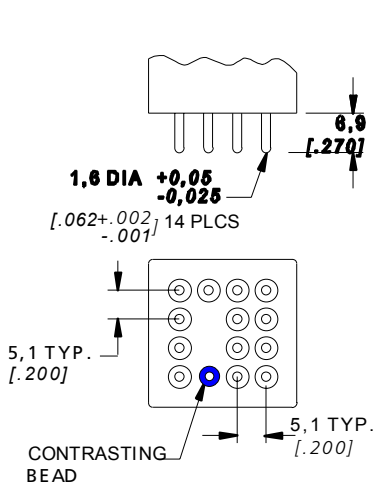

SOLDER PIN

STYLE A: TIN PLATED
STYLE B: SOLDER DIPPED

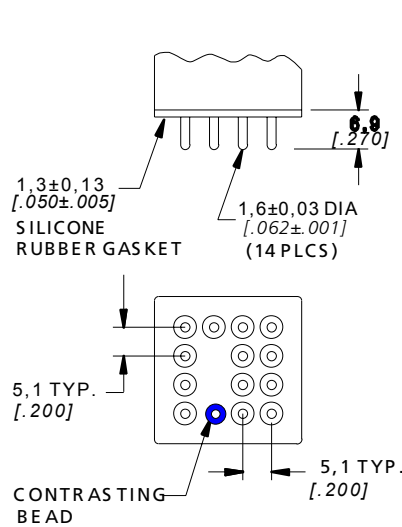

PLUG IN (DC)

STYLE C: GOLD PLATED

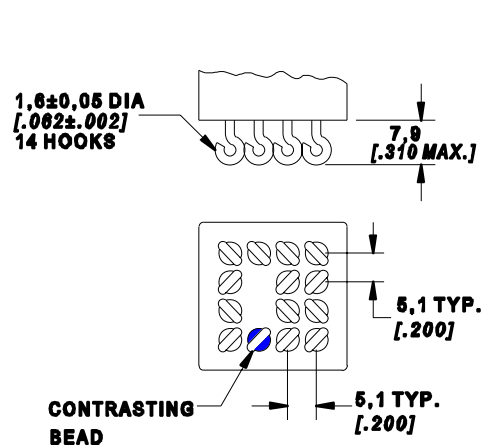

SOLDER HOOK

STYLE H: TIN PLATED
STYLE J: SOLDER DIPPED

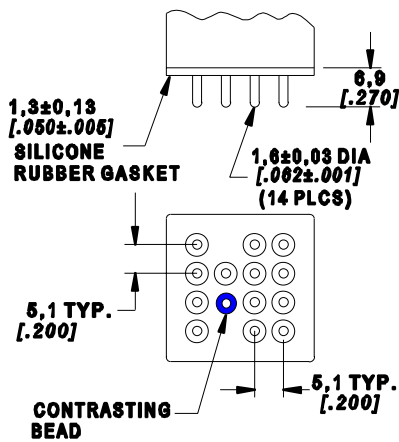

PLUG IN (115 VAC)

STYLE K: GOLD PLATED WITH GASKET
STYLE L: TIN PLATED WITHOUT GASKET

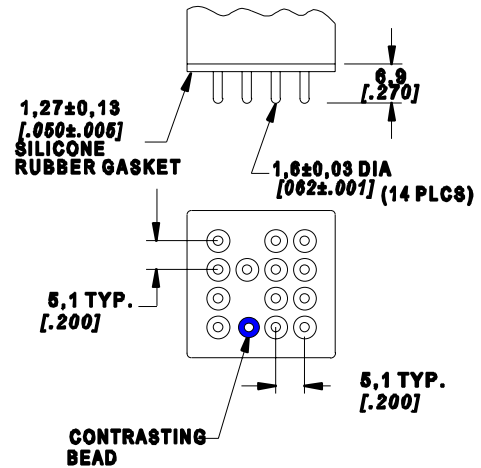

PLUG IN (28 VAC)

STYLE T: GOLD PLATED WITH GASKET
STYLE U: TIN PLATED WITHOUT GASKET

Coil characteristics

COIL CODE	DC						AC	
	A	B	D	E	G	J	L	N
Nominal coil voltage	6	12	26.5	28	48	110	115-400 Hz	115-50/60/400 Hz
Maximum pick-up voltage at 25°C	3.2	6.5	13.5	14	24	55	73	73
Maximum pick-up voltage at 125°C	4.5	9.0	18	18.7	36	70	90	90
Minimum drop-out voltage at -70° C	0.25	0.5	1.2	1.5	2	5	5	5
Maximum hold voltage at 125°C	2.3	4.5	7.0	7.0	14	30	30	40
Coil resistance (ohms ± 10% at 25° C)	10	40	210	210	620	3200	-	-
Maximum coil transient suppression	42	42	42	42	100	180	-	-

OTHER VOLTAGES AVAILABLE FROM FACTORY ON REQUEST

Circuit diagram

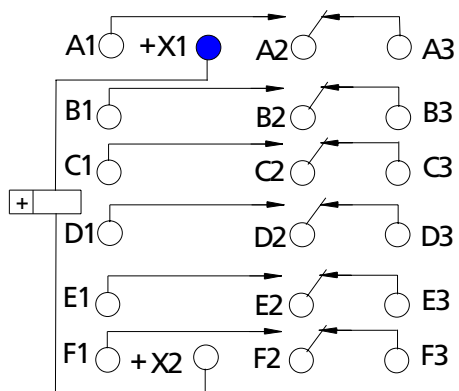

E610/E615

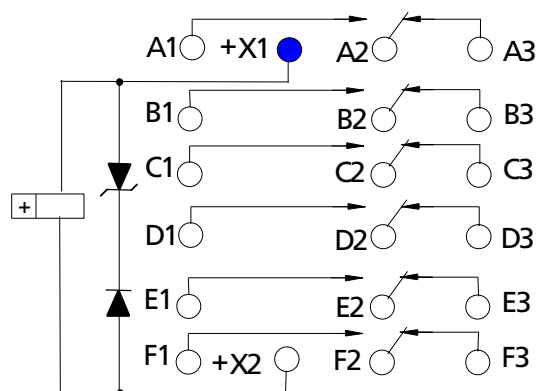

ES610/ES615
OPTIONAL INTERNAL
VOLTAGE SUPPRESSOR

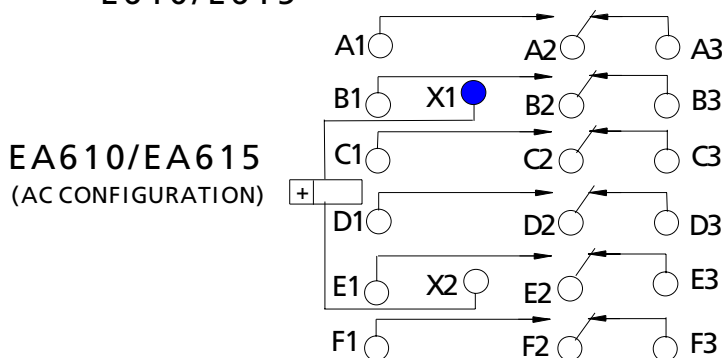

EA610/EA615
(AC CONFIGURATION)

Mounting Styles

DIMENSIONS ARE IN MM (IN.)
UNLESS OTHERWISE SPECIFIED, TOLERANCE IS $\pm 0,25$ [.010]

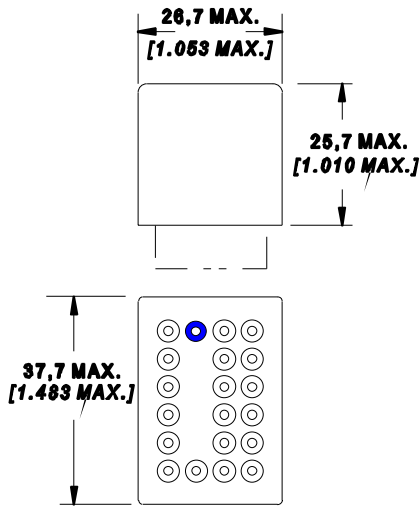

STYLE 1
NO MOUNT

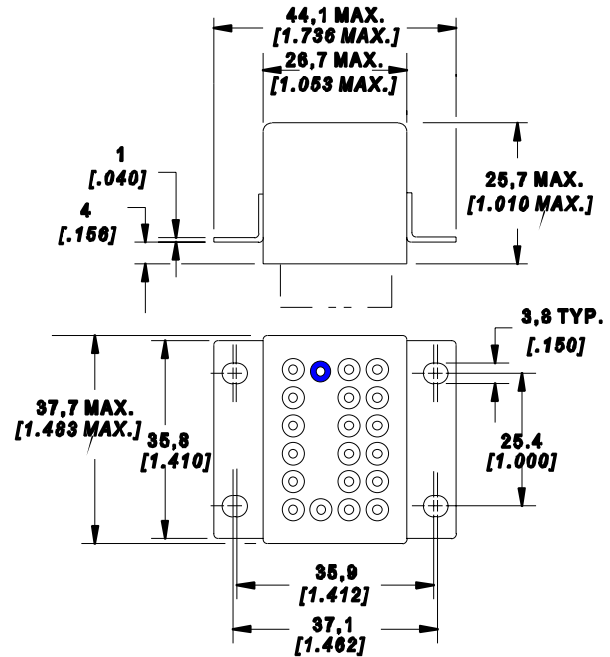

STYLE 2
RAISED VERTICAL FLANGE MOUNT

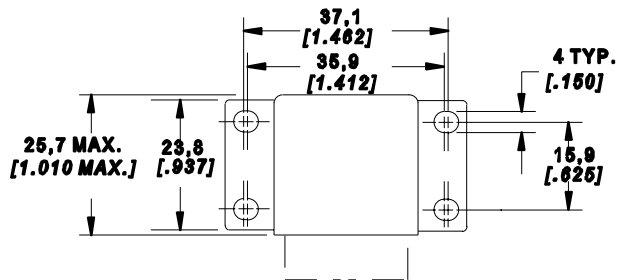

STYLE 3
HORIZONTAL FLANGE MOUNT

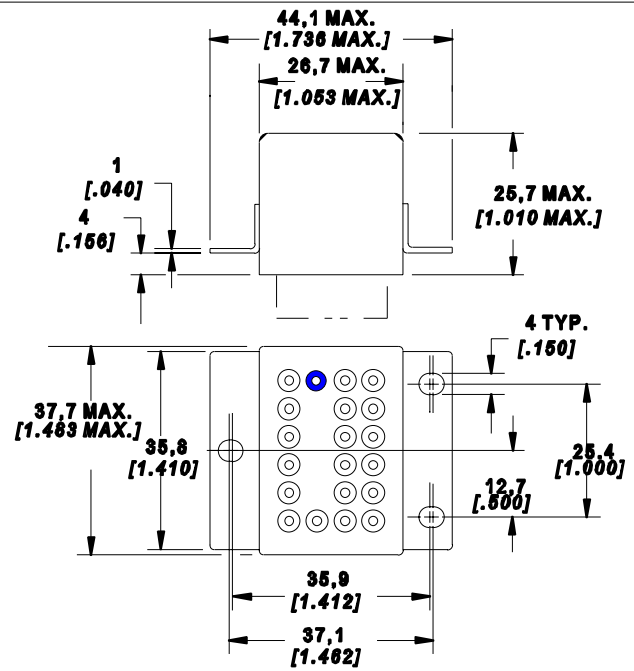

STYLE H
RAISED VERTICAL FLANGE MOUNT
(3 MOUNTING HOLES)

■ Mounting styles

DIMENSIONS ARE IN MM (IN.)
UNLESS OTHERWISE SPECIFIED, TOLERANCE IS $\pm 0,25$ [.010]

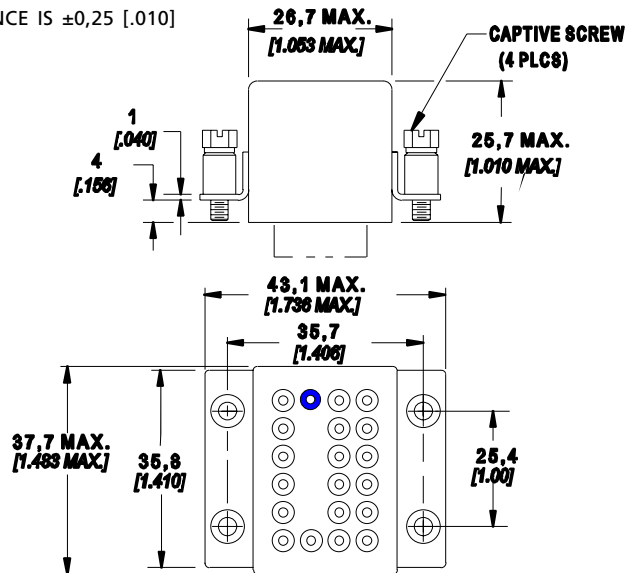

STYLE 8: M3 CAPTIVE SCREWS

STYLE C: #4-40 UNC CAPTIVE SCREWS

RAISED VERTICAL FLANGE MOUNT
WITH CAPTIVE HARDWARE

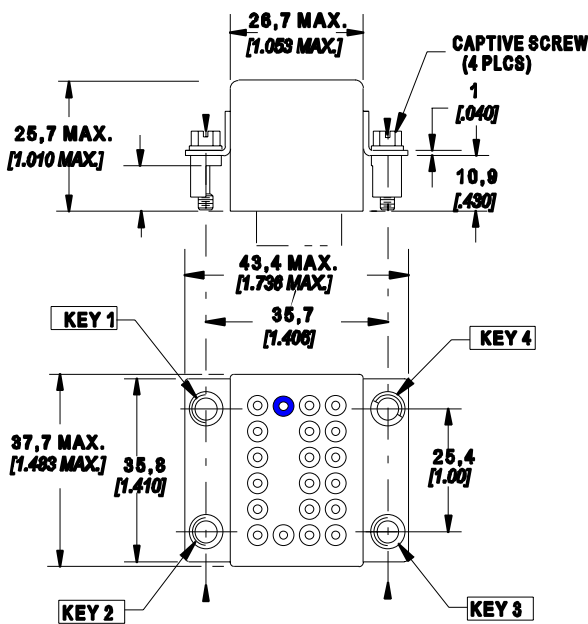

KEYING SYSTEM
WITH CAPTIVE HARDWARE

STYLE N: M3 CAPTIVE SCREWS

STYLE P: #4-40 UNC CAPTIVE SCREWS

KEYING POSITIONS

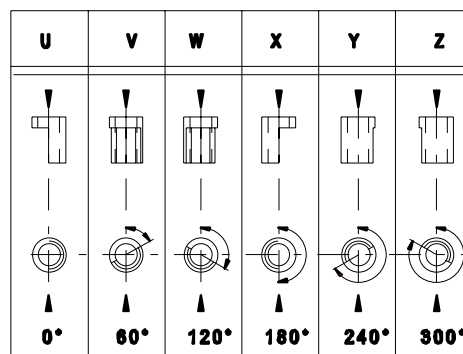

COIL	KEY 1	KEY 2	KEY 3	KEY 4	SUPPRESSED			
					KEY 1	KEY 2	KEY 3	KEY 4
6 VDC	V	Z	V	U	V	Z	X	U
12 VDC	X	Z	V	U	V	Z	X	U
26.5 VDC	U	X	V	Z	Y	X	W	Z
28 VDC	V	X	V	Z	Y	X	V	Z
48 VDC	V	Z	U	U	V	Z	W	U
110 VDC	X	Z	U	U	X	Z	W	U
115 VAC	U	Z	V	U				

KEYING CONFIGURATION SHOWN IN TABLE COMES STANDARD
WITH SPECIFIED COIL VOLTAGE. FOR ORDERING OTHER
KEYING POSITIONS USE 4 DIGIT (XXXX)
"SPECIAL INSTRUCTIONS" ON END OF P/N.
EX: E610BACWVZX

Termination Styles

DIMENSIONS ARE IN MM (IN.)
UNLESS OTHERWISE SPECIFIED, TOLERANCE IS $\pm 0,25$ [.010]

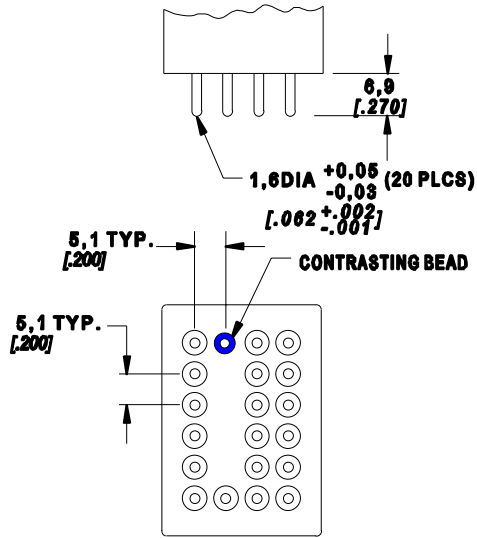

SOLDER PIN

STYLE A: TIN PLATED
STYLE B: SOLDER DIPPED

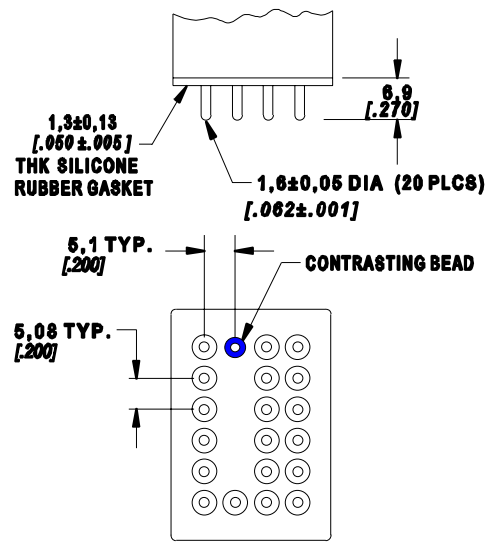

PLUG IN (DC)

STYLE C: GOLD PLATED

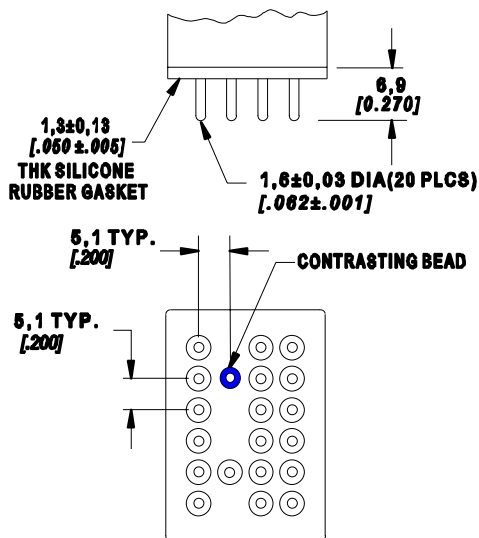

PLUG IN (AC)

STYLE K: GOLD PLATED WITH GASKET
STYLE L: TIN PLATED WITHOUT GASKET

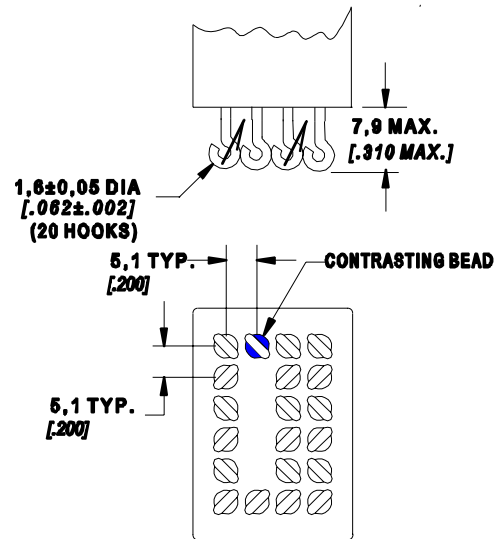

SOLDER HOOK

STYLE H: TIN PLATED
STYLE J: SOLDER DIPPED