

Commerical EMI Bulkhead-Mounted Receptacle & Cable-Mounted Plug

To meet the EMI and ESD requirements of certain electrified vehicle, energy storage system or control system applications, Rebling offers its two-pole, quick-disconnect EMI-shielded connectors. Our patented bulkhead-mounted EMI receptacle (7009-51) is created using a multiple stage injection molding process which surrounds the receptacle's silver-plated copper pins with non-conductive black plastic which is, in turn, surrounded by conductive gray plastic. The conductive gray plastic of the bulkhead-mounted receptacle is grounded to the metal bulkhead as well as to the conductive gray plastic backshell of the cable-mounted plug connector (7020-E) via a conductive gasket (643A1625). The EMI receptacle and plug are not keyable, but can be used with the optional magnetic HVIL switch (643A1757).

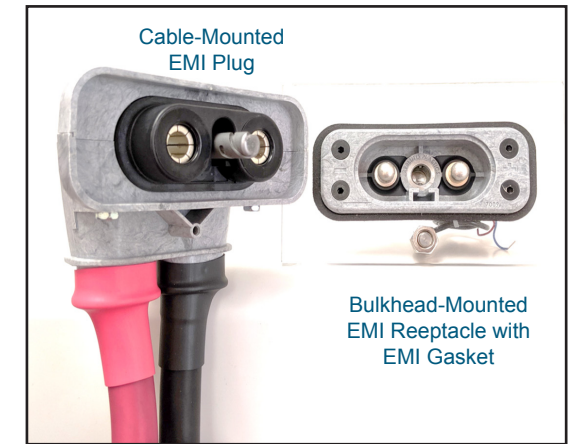

7009-51 Bulkhead-mounted Receptacle

ELECTRICAL

Current

▶ Continuous Rated Current (CRC) (per UL1977)	400 amp
▶ Current Profile #2 - 50% CRC for 60min + 1 sec peak + 50% CRC for 60 min	2,200 amp
▶ Current Profile #3 - 50% CRC for 60min + 10 sec peak + 50% CRC for 60 min	1,500 amp
▶ Current Profile #4 - 50% CRC for 60min + 30 sec peak + 50% CRC for 60 min	1,000 amp
▶ Current Profile #5 - 50% CRC for 60min + 60 sec peak + 50% CRC for 60 min	800 amp

Voltage

▶ Rated Voltage (volts, continuous)	1,000
▶ Dielectric Withstanding Voltage (volts, AC or DC)	4,000

Contact Resistance Max (Micro Ohms)

70

HVIL Circuit

Yes - Optional

EMI Shielded

Yes

MECHANICAL

Wire Size Range

▶ Maximum Wire Size	4/0
▶ Maximum Cable OD (inches)	1.1
▶ Maximum Terminal Lug Tongue Width (inches)	0.80
▶ Maximum Terminal Lug Web Width (inches)	0.24

Environmental Sealing when mated

▶ With standard kit components	IP56
▶ With optional gasket	IP68

Operating Temperature

▶ Minimum (°C)	-40°
▶ Maximum (°C)	90°

Flammability Rating (per UL94)

V-0

Mechanical Shock

50gs - 3 axes

Vibration

10gs - 3 axes

Mating Cycles

▶ No Electrical Load	5,000
▶ Live Electrical Load (24 volts & 100amps)	100

Torque on Electrical Connections

▶ Recommended	30-40 in-lbs
▶ Material Failure	80 in-lbs

CERTIFICATIONS

UL Conformance
RoHS Compliance

Certificates are downloadable from Rebling.com
All parts itemized on this datasheet are RoHS compliant

7020-E Cable-Mounted Plug

ELECTRICAL

Current

▶ Continuous Rated Current (CRC) (per UL1977)	400 amp
▶ Current Profile #2 - 50% CRC for 60min + 1 sec peak + 50% CRC for 60 min	2,200 amp
▶ Current Profile #3 - 50% CRC for 60min + 10 sec peak + 50% CRC for 60 min	1,500 amp
▶ Current Profile #4 - 50% CRC for 60min + 30 sec peak + 50% CRC for 60 min	1,000 amp
▶ Current Profile #5 - 50% CRC for 60min + 60 sec peak + 50% CRC for 60 min	800 amp

Voltage

▶ Rated Voltage (volts, continuous)	1,000
▶ Dielectric Withstanding Voltage (volts, AC or DC)	4,000

Contact Resistance Max (Micro Ohms)

70

HVIL Circuit

Yes - Optional

EMI Shielded

Yes - Optional

MECHANICAL

Wire Size Range

▶ Maximum Wire Size	4/0
▶ Maximum Cable OD (inches)	0.82
▶ Maximum Terminal Lug Tongue Width (inches)	1.08
▶ Maximum Terminal Lug Web Width (inches)	0.45

Environmental Sealing when mated

▶ With standard kit components	IP55
▶ With optional, shrink tubing	IP56

Operating Temperature

▶ Minimum (°C)	-40°
▶ Maximum (°C)	90°

Flammability Rating (per UL94)

V-0

Mechanical Shock

50gs - 3 axes

Vibration

10gs - 3 axes

Mating Cycles

▶ No Electrical Load	5,000
▶ Live Electrical Load (24 volts & 100 amps)	100

Mating Force

▶ Maximum Mating or Unmating torque after 10 matings	12 in-lbs
▶ Maximum Mating or Unmating torque after 5,000 matings	12 in-lbs

Torque on Electrical Connections

▶ Recommended	30-40 in-lbs
▶ Material Failure	80 in-lbs

CERTIFICATIONS

UL Conformance
RoHS Compliance

Certificates are downloadable from Rebling.com
All parts itemized on this datasheet are RoHS compliant

Rebling Datasheet Commercial EMI Bulkhead-Mounted Receptacle & Cable-Mounted Plug



P/N	Description	Plastic Color	Weight (Grams)	UL 94 Rating	Plastic Material #
7009-51	Receptacle, EMI, With Threaded Posts*	Gray	115	V-0	000A1272 000A1854
643A1625	Conductive EMI Gasket for 7009-51	Black	10	V-0	000A1863
643A1757	HVIL Switch & Magnet Kit	Black	25	-	-
7020-E	Cable-mounted with EMI-ESD conductive Gray Backshell**	Gray	300	V-0	000A1272
-	Backshell 7020-E included in Kit (no H/W)	Gray	88	V-0	000A1854
-	T-Handle for 7020-E included in kit	Black	15	V-0	000A1861

*7009-51 Receptacle includes two silver plated conductive spacers, 5/16 nuts and 5/16 split washers
 **7020-E Plug includes 5/16 bolts, 5/16 split washers, 10/32 x 13/4 bolts and 10/32 hex locknut



MOUNTING and ASSEMBLY

Mounting Hole Pattern (see diagram)

Recommended Torque on Electrical Connection bolts

30 to 40 in-lbs

Application Recommendations

- ▶ When attaching 4/0 cable to the 7009-51 rear threaded posts, use Burndy narrow tongue crimp lugs
- ▶ #8 or M4 flathead 82 degree screws recommended for mounting the 7009-51 to the bulkhead
- ▶ Assembly of the EMI Bulkhead-mounted Receptacle: each 7009-51 EMI Shielded Receptacle is packaged with two nuts, two split washers and two silver plated conductive spacers. A conductive spacer should be placed on each threaded post first, then the cable terminal lug, then the split washer, then the nut. The purpose of the conductive spacer is to provide sufficient distance between the cable lug and the connector's conductive gray plastic body to achieve the required dielectric strength.
- ▶ Assembly of the EMI Cable-mounted Plug: use the 5/16 stainless bolts to attach the cable crimp lugs to the plug connector's terminals then attach the conductive backshell to the connector using the 10-32 bolts and lock nuts. If using individually shielded cables, pig-tail or flare-out each cable's shielding braid and use a metal or plastic zip tie to secure the braid to the cable entrance tunnel of the plug connector's conductive backshell. If using a conductive sheath which encompasses both cables, use a metal or plastic zip tie to secure the sheath around both cable entrance tunnels of the plug connector's conductive backshell.
- ▶ Resistivity Testing of Conductive Plastic: the plastic used in Rebling's EMI-shielded connectors is infused with conductive nickel fibers. The resistivity/conductivity of a fiber-infused material cannot be measured at a single point using the sharp tipped probes found on a multimeter, it must be measured with a surface-area probe, not a sharp-tipped probe. Measurement of a conductive plastic's resistivity/ conductivity can be achieved by placing a 10 mm diameter metal disk on the surface of the conductive plastic then touching the disk with a sharp-tipped multimeter probe.
- ▶ Optional HVIL Switch - HVIL Kit P/N 643A1757 includes a 1/8" x 5/8" cylindrical neodymium magnet which is inserted into a cylindrical opening on the face of the cable-mounted plug which aligns with the magnetic reed switch which is mounted on the panel below the bulkhead-mounted receptacle
- ▶ Torque on Backshell Bolts

6 to 8 in-lbs

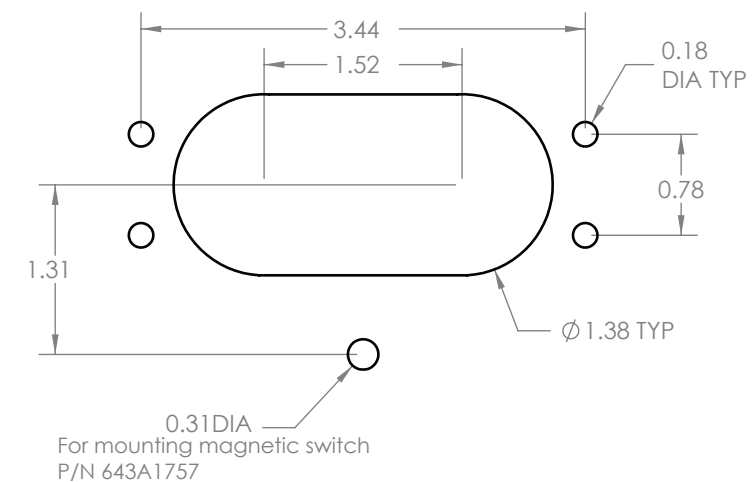
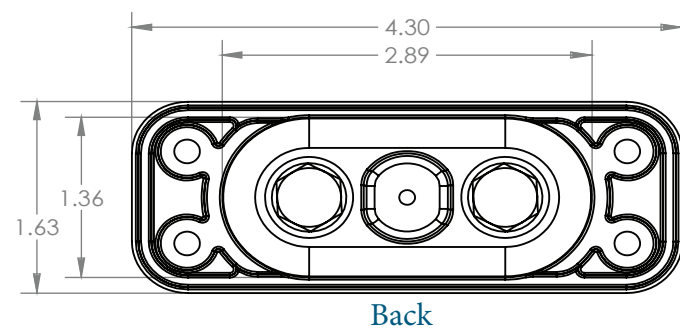
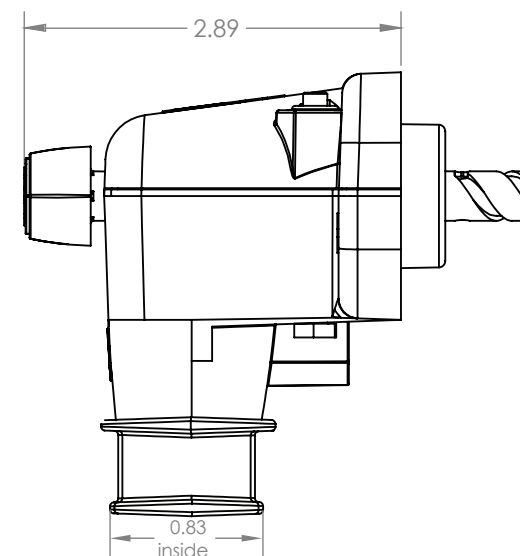
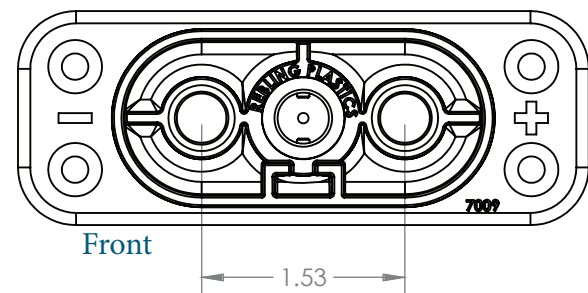
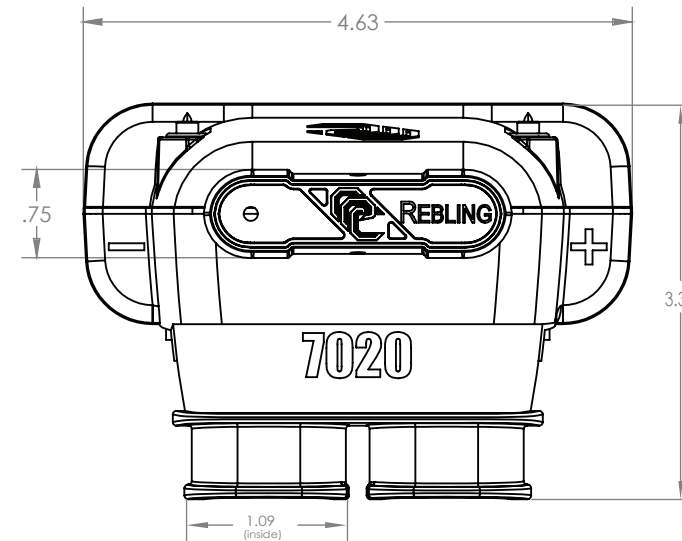
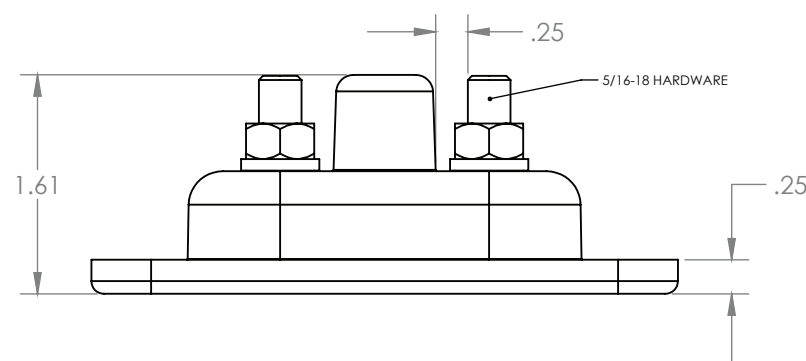

Mounting Hole Pattern (inches)