

CIRCUIT BREAKERS





Standard

Single-Pole High Performance

Qualified

To MIL-C-5809 and MS25361.

Protection For Heavy-Duty Systems

Protects circuits from 50 to 100 amperes.

Heavy-Duty Construction

Breaker features large contacts and wide terminals.

Not Sensitive To Frequency

May be used on either AC or DC circuits.

Performance Rated Circuit Breaker

The 160 series has the recognition of being the most specified heavy-duty aircraft type circuit breaker in the 50 to 100 ampere rating range.

Designed to protect heavy-duty aircraft and non-aircraft electrical systems, this trip-free breaker features separate, durable, overload and mechanical latches. In addition, the overload latch is designed for precise operation. Extra heavy contacts are spring-loaded to maintain high-contact pressure and assure long life. Contact material has high resistance to arcing and the corrosive action of moisture —thus assuring low voltage drop throughout the life of the breaker.

PERFORMANCE DATA

Interrupting Capacity	6,000A at 30V, DC; 3,500A at 120V, 400 Hz., AC
Endurance	At 120VAC, 400 Hz.: inductive load — 5,000 cycles; resistive load — 5,000 cycles; at 30V, DC: inductive load — 2,500 cycles; resistive load — 5,000 cycles; mechanical cycling, no load — 5,000 cycles
Overload Cycling	100 operations at 200% rated current and rated voltage
Dielectric Strength	At sea level, 25°C 1,500V, AC. At 70,000 ft., 71°C 500V, AC
Insulation Resistance	Not less than 100 megohms at 500V, DC
Voltage Drop	0.15V, maximum
Vibration	Meets specification MIL-STD-202, Method 204, Condition A-10G, 10-500 Hz.
Shock	Exceeds 30G's, 11 Millisec (half-sine pulse) MIL-STD-202, Method 213 Test J
Acceleration	Exceeds 10G's
Weight	113 grams (0.25 lbs.)

OVERLOAD CALIBRATION DATA

Specification Table	@ 25°C		@ +71°C		@ -40°C		Test Time Parameters
	MIN	MAX	MIN	MAX	MIN	MAX	
Must Hold	105	—	70	—	125	—	% For 1 Hour
Must Trip	—	138	—	125	—	165	% Within 1 Hour
200% Overload	15	65	—	—	—	—	Seconds
400% Overload	2	10	—	—	—	—	Seconds
600% Overload	1	4	—	—	—	—	Seconds

Trip curve available

ORDERING INFORMATION

MS APPROVAL STATUS	AMPERE RATING	VOLTAGE DROP MAX. *	STANDARD		HIGH VIBRATION	
			MS P/N	LABINAL MP P/N	MS P/N	LABINAL MP P/N
MS Approved	50	0.15	MS25361-50	160-012-50	MS25361-50V	160-086-50
MS Approved	60	0.15	MS25361-60	160-012-60	MS25361-60V	160-086-60
MS Approved	70	0.15	MS25361-70	160-012-70	MS25361-70V	160-086-70
MS Approved	75	0.15	MS25361-75	160-012-75	MS25361-75V	160-086-75
MS Approved	80	0.15	MS25361-80	160-012-80	MS25361-80V	160-086-80
MS Approved	90	0.15	MS25361-90	160-012-90	MS25361-90V	160-086-90
MS Approved	100	0.15	MS25361-100	160-012-100	MS25361-100V	160-086-100

* AT RATED NOMINAL CURRENT

3 Phase variants are available as a 940 Series.

For other amperage ratings and configurations, consult the Business Unit.

DIMENSIONS

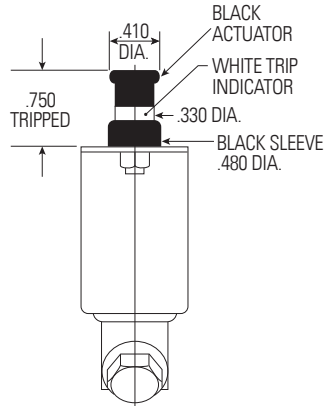
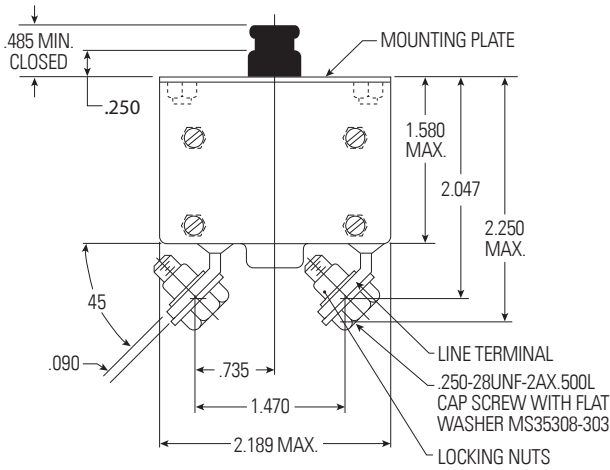
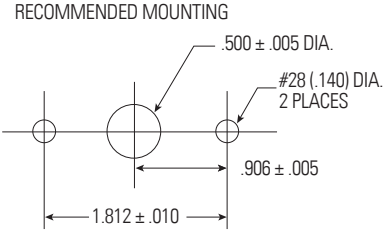
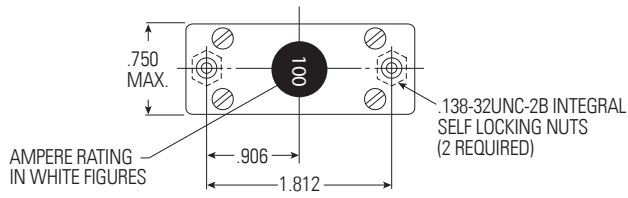

TRIP CURVE

