



# Three Phase TC Series Circuit Breakers

Miniature Ambient Compensated

## Features

- **One phase trips all**
- **Protective shields between each phase's terminals**
- **Pads increase mounting stability**
- **Also includes identical features as 2TC and 3TC**

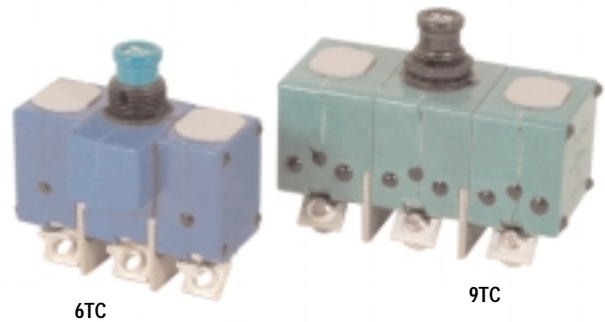

## Overview

The 6TC and 9TC circuit breakers provide ambient compensated circuit protection in a lightweight, subminiature package size. The three phase design integrates each individual phase to provide overcurrent protection in the event of simultaneous or unbalanced overloads, including short circuit conditions.

## Coordination

The 6TC and 9TC are compatible with their single phase 2TC and 3TC cousins. The 6TC and 9TC are available in ratings from 1-35 amps, with military and various commercial approvals on most styles.

## Ambient Temperature Compensation

The 6TC and 9TC are ambient compensated circuit breakers. This allows usage of smaller gauge wire.

The 6TC and 9TC can operate over a temperature range of -54°C to 121°C, however, care should be taken to understand the specification limits at elevated ambient temperatures.

## Options\*

- Longer push buttons
- High vibration
- Metric mounting thread
- Metric terminal thread
- Dust boot†
- Auxiliary switch device available††

\* Contact factory for details

† Part Number 14500-1 fits 15/32 bushing  
Part Number 14500-5 fits 7/16 bushing

†† 6TC Device

## Trip Free

The complete line of TC series circuit breakers is trip free. The circuit breaker cannot be maintained closed during an overload, even with the actuator button held closed.

## High Short Circuit Capacity

For its miniature size, the 6/9TC series offers unusually high current interrupting capacity. Overloads up to 2000 amps at 120 VAC, 400 Hz can be safely interrupted without affecting calibration or operating performance in the standard 6/9TC series.

## Qualifications

MS14154	6TC2
MS14154L	6TC37
MS14154V	6TC63
MS14153	9TC2

European standards  
SAE standards  
All U.S. aircraft OEM's  
Most European aircraft OEM's

## Characteristics

6/9TC

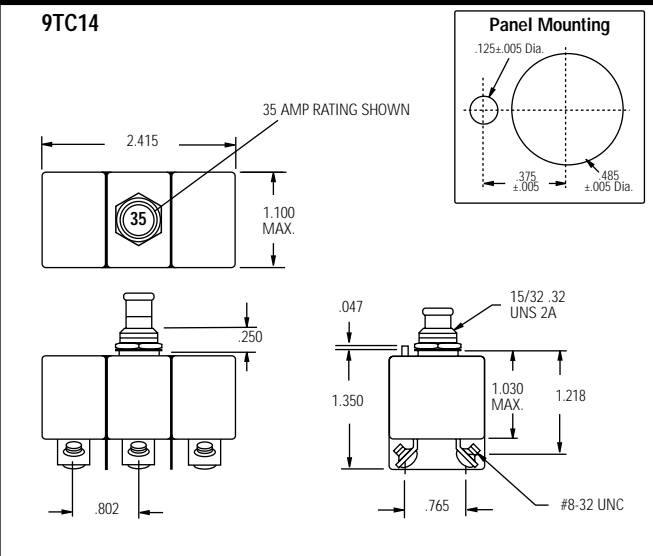
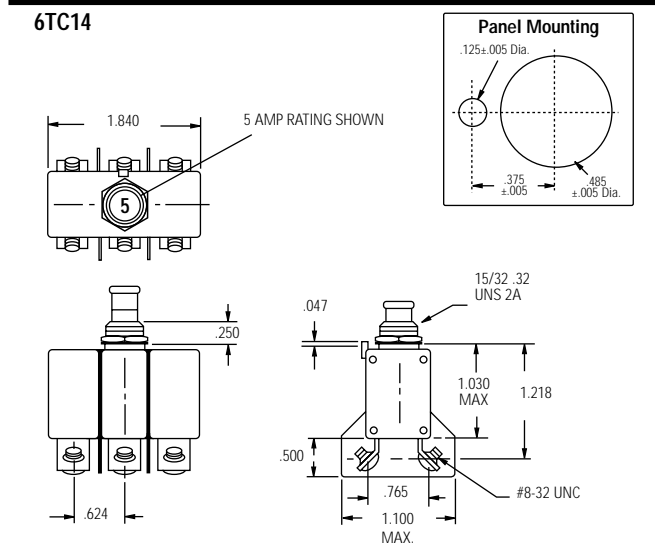

### Calibration: 2-20 amps

TEMP °C	MIN ULT TRIP	MAX ULT TRIP	TRIP TIME - SECONDS		
			200%	500%	1000%
+25	110%	145%	4-20	.40-2.0	.10-.53
-54	110%	165%	6-40	.55-3.5	.15-.80
+90	100%	145%	3-20	.33-1.7	.08-.40
+121	90%	145%	3-20	.33-1.7	.08-40

† Single phase max. ult. trip values apply with other two phases carrying 100% of rated current.

Vibration\* ..... 10 G's minimum, 50-500 Hz  
 Mechanical Shock ..... 50 G's  
 Acceleration ..... 10 G's  
 Weight ..... 6TC14 - 65 gm max.  
 ..... 9TC14 - 110 gm max.

### Interrupt Current

2-20 amps: 2000 amps at 120 VAC, 400 Hz  
 1, 15-35 amps: 2000 amps at 120 VAC, 400 Hz

### Endurance

2500 cycles ..... 120 VAC, 400 Hz Inductive  
 5000 cycles ..... 120 VAC, 400 Hz Resistive  
 5000 cycles ..... Mechanical, no load

\* Other vibration levels available. Contact factory for details.

### Calibration: 1, 15-35 amps

TEMP °C	MIN ULT TRIP	MAX ULT TRIP	TRIP TIME - SECONDS		
			200%	500%	1000%
+25	110%	145%	4-20	.40-2.0	.10-.53
-54	110%	165%	6-40	.55-3.5	.15-.80
+90	100%	145%	3-20	.33-1.7	.08-.40
+121	90%	145%	3-20	.33-1.7	.08-40

† Single phase max. ult. trip values apply with other two phases carrying 100% of rated current.

TI Number	Voltage Drop (max.)
6TC14-2	0.70
6TC14-2½	0.50
6TC14-3	0.40
6TC14-4	0.37
6TC14-5	0.35
6TC14-7½	.192
6TC14-10	.176
6TC14-15	.176
6TC14-20	.176

TI Number	Voltage Drop (max.)**
9TC14-1	1.10
9TC14-15	0.25
9TC14-20	0.25
9TC14-25	0.25
9TC14-30	0.25
9TC14-35	0.25

\*\* Max voltage drop at nominal rated current.  
 (25 amp 6TC pending qualification.)

### Approximate Time-Current Curves - 6TC and 9TC Circuit Breakers

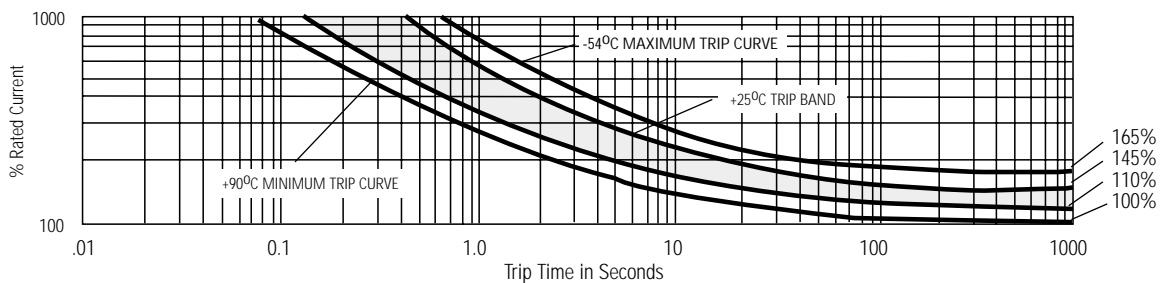

REVISIONS					
ZONE	LTR	DESCRIPTION	1112	DATE	APPROVED
	B	MODIFIED PRINT PER MARK-UP	ECN0025546 GML	12-20-05	D.M.

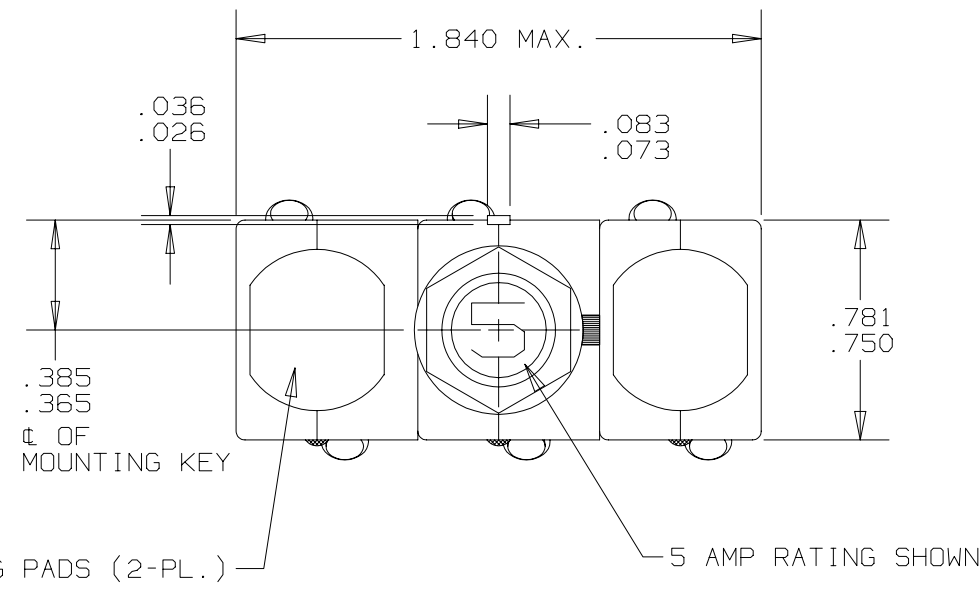

PERFORMANCE CHARACTERISTICS

DETAIL PERFORMANCE PER MIL-C-5809 AND MS14154 "V"

OVERLOAD CYCLING	-----	100 CYCLES AT 200% RATING
VIBRATION	-----	10 G'S CONDITION "C" 55-2000 Hz AND 15 G'S CONDITION "B" 10-2000 Hz
MECHANICAL SHOCK	-----	50 G'S
ACCELERATION	-----	10 G'S
SAND AND DUST	-----	12 HOURS
CORROSION	-----	SALT SPRAY 50 HOURS
HUMIDITY	-----	10 DAYS
EXPLOSION PROOF	-----	WHILE INTERRUPTING RUPTURE CURRENTS

ENDURANCE:	120 VAC	400 HZ INDUCTIVE	2500 CYCLES
		400 HZ RESISTIVE	5000 CYCLES
		NO LOAD	5000 CYCLES

SINGLE * OR THREE PHASE CALIBRATION:	2 AMP THRU 20 AMP				
	MIN. ULT. TRIP	MAX. ULT. TRIP	200%	500%	1000%
+25°C, +77°F	110% RATING	145% RATING	4-20 SEC.	.40-2.0 SEC.	.10-.53 SEC.
-55°C, -65°F	110% RATING	165% RATING	6-40 SEC.	.55-3.5 SEC.	.15-.80 SEC.
+71°C, +160°F	100% RATING	145% RATING	3-20 SEC.	.33-1.7 SEC.	.08-.40 SEC.

RUPTURE:	2 AMP THRU 20 AMP	120 VAC, 400 HZ	2000 AMPS
----------	-------------------	-----------------	-----------

MAXIMUM OPERATING FORCES			
PULL OUT	-----	12 LBS. MAX.	(53.4 N)
RESET	-----	12 LBS. MAX.	(53.4 N)

OPERATING ALTITUDE: 70,000 FT. (21,000 M)

WEIGHT: 65.0 GRAMS MAX. (.143 LBS.)

VOLTAGE DROP:		
2 AMP	-----	0.70 VOLTS MAX.
2.5 AMP	-----	0.50 VOLTS MAX.
3 AMP	-----	0.40 VOLTS MAX.
4 AMP	-----	0.37 VOLTS MAX.
5 AMP	-----	0.35 VOLTS MAX.
7.5 AMP	-----	.192 VOLTS MAX.
10 AMP	-----	.176 VOLTS MAX.
12 AMP	-----	.211 VOLTS MAX.
15 AMP	-----	.176 VOLTS MAX.
20 AMP	-----	.176 VOLTS MAX.

\* SINGLE PHASE MAXIMUM ULTIMATE TRIP VALUES APPLY WITH OTHER TWO PHASES CARRYING 100% OF RATED CURRENT

NOTES:

- EPOXY SURFACES ARE NON-DIMENSIONED. ENVELOPE DRAWING DIMENSIONS DO NOT APPLY TO THESE PROJECTED EPOXY SURFACES.
- TERMINAL AND MOUNTING HARDWARE MAY BE PACKAGED RATHER THAN INSTALLED.
- COUNTRY OF ORIGIN IS SHOWN FOR ILLUSTRATION PURPOSES ONLY. COUNTRY OF ORIGIN TO BE IDENTIFIED AS REQUIRED.
- DATE CODE PER 10588-285.
- ALL MARKINGS TO BE MADE IN APPROXIMATE POSITIONS SHOWN WITH BLACK INK PER 12506-70. 3/32 HIGH CHARACTERS.

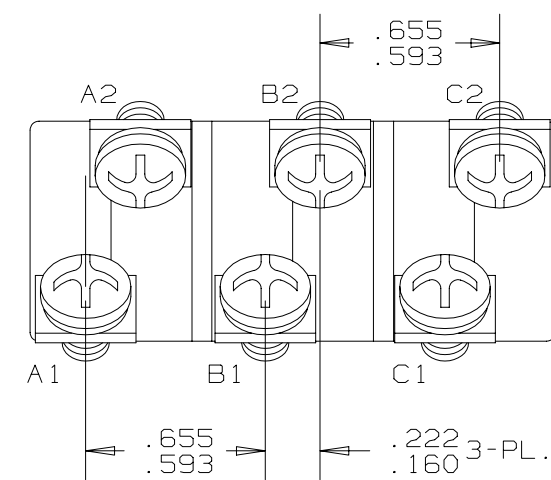
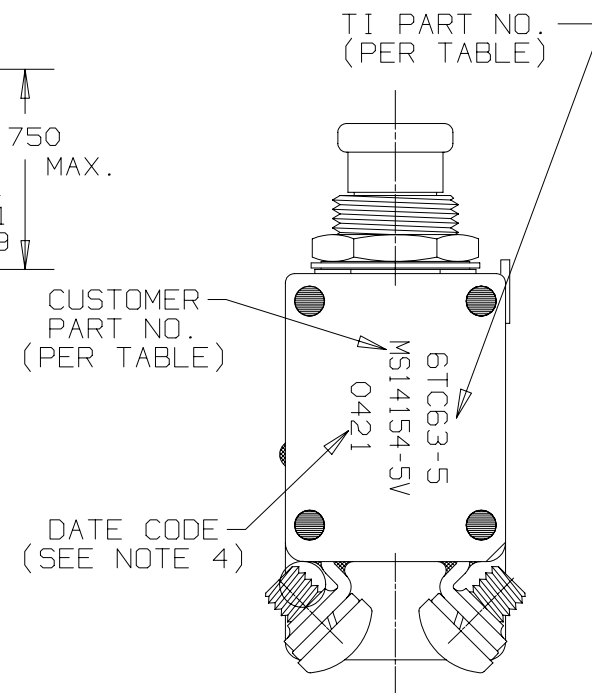
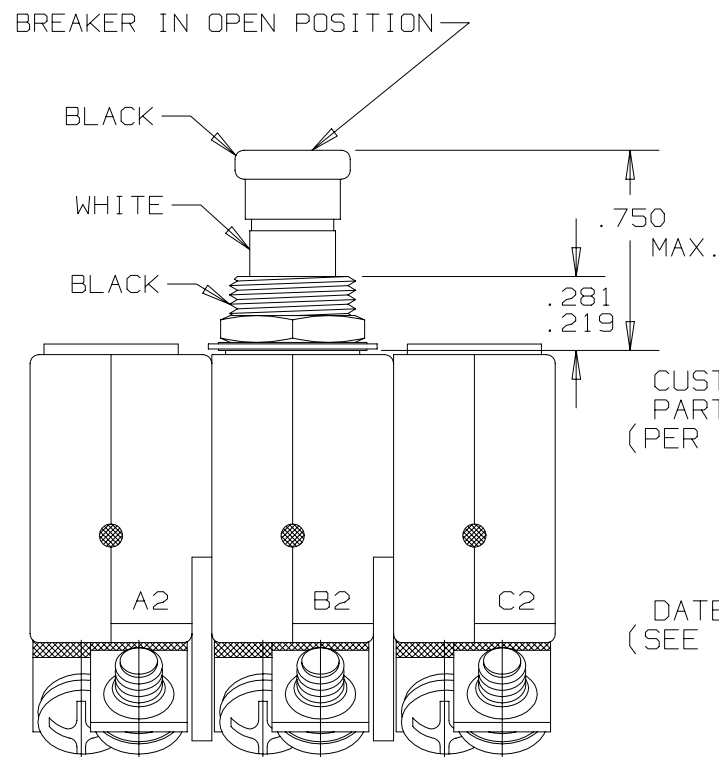
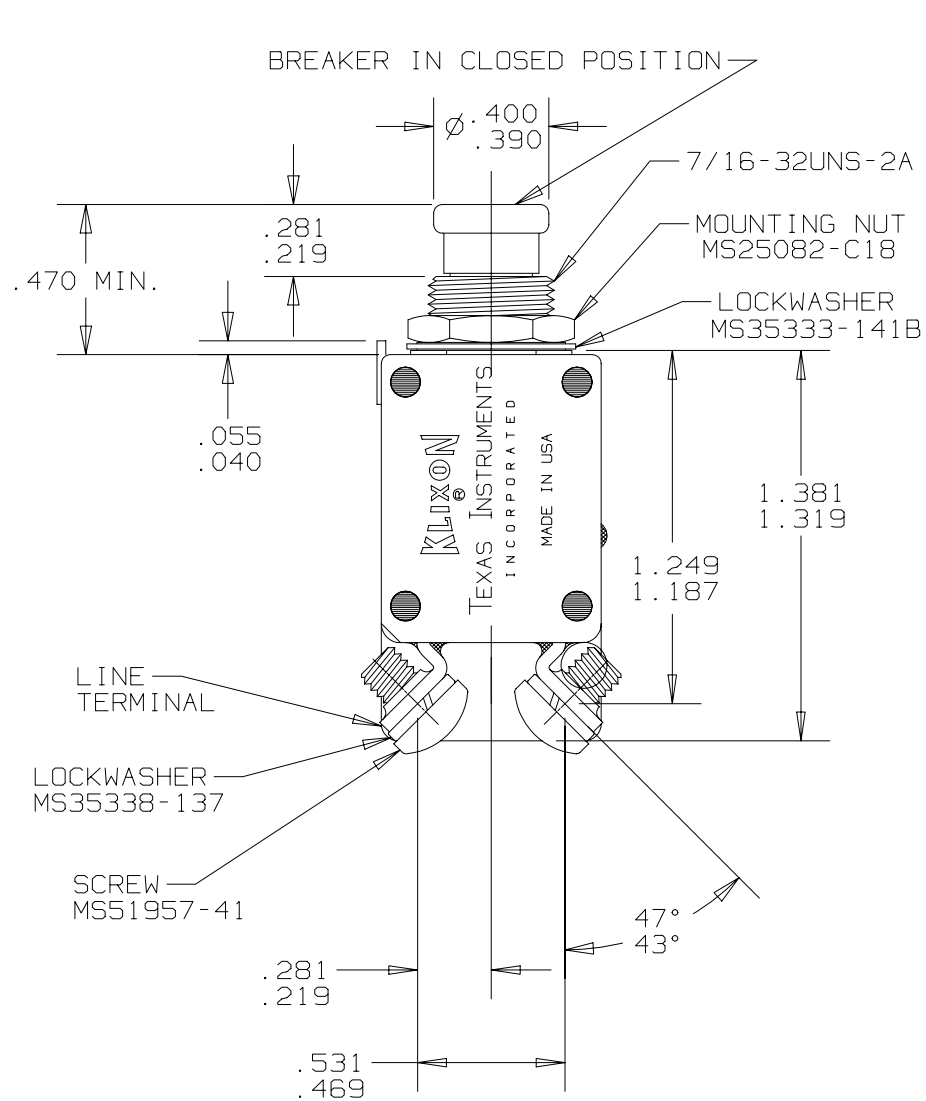

TI PART NO.	CUSTOMER PART NO.
6TC63-20	MS14154-20V
6TC63-15	MS14154-15V
6TC63-10	MS14154-10V
6TC63-7 1/2	MS14154-7 1/2V
6TC63-5	MS14154-5V
6TC63-4	MS14154-4V
6TC63-3	MS14154-3V
6TC63-2 1/2	MS14154-2 1/2V
6TC63-2	MS14154-2V

UNLESS OTHERWISE SPECIFIED DIMENSIONS ARE IN INCHES		DRAWN JM	DATE 02-12-95	TEXAS INSTRUMENTS ATTLEBORO, MASSACHUSETTS 02703	KLAXON CONTROL PRODUCTS DIVISION
TOLERANCE ON FRACTIONS DECIMALS ANGLES		ENGINEER M.A. VIDAL	DATE 02-12-95		
MATERIAL		APPROVED		TITLE PART NO: 6TC63 AMBIENT COMPENSATED CIRCUIT BREAKER PUSH-PULL, TRIP FREE ENVELOPE DRAWING	
		APPROVED		SIZE	CODE IDENT NO.
		SIGNATURES ON FILE. REFER TO ELECTRONIC CHANGE NOTICE.		C	82647
				SCALE: 4X	6TC63
				SHEET 1 OF 1	