



KLIXON® | F Series (FDLM, FDLA, FDLS, FDLT)

35 to 150 Amp Surface Mounted Thermal Circuit Breaker

FEATURES

- 30VDC, 35 to 150 Amps
- Weatherproof, ignition protected, trip-free design
- Stronger housing material for increased robustness
- Ability to accommodate heavy gauge wire lugs across terminal studs
- SAE J1625 surface vehicles circuit breaker standards
- SAE J1171 marine circuit breaker standards
- Meets 5000 amps @ 12VDC for interrupt capacity per ABYC E-11, DC electrical systems of boats

DESCRIPTION

The KLIXON® F series thermal breaker series are designed for surface mount applications and are available with automatic trip, manual reset, trip indication, and a switchable option in a single device. The internal components are enclosed in a vibration resistant, weatherproof, robust casing to provide protection in the harshest environments found in heavy truck, off-road, marine and construction applications. The F series thermal breakers are designed to combine trip-free protection with fast response time. Terminal studs are available in 1/4" or a larger 3/8" option to allow higher torque connections and provide wider spacing for heavy gauge wire lugs.

ORDERING INFORMATION

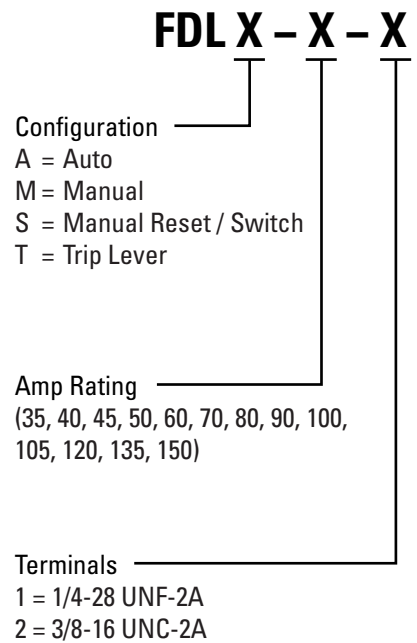

PERFORMANCE CHARACTERISTICS

| | |
|---|-----------------------------------|
| Calibration : 200% rated current, 77°F (25°C) | 35 to 150 Amps : 8 to 100 seconds |
| Ultimate Trip At 77°F (25°C) | Must hold 100%, Must trip 135% |
| Endurance | Per SAE J1625 |
| Interrupt Current Capacity | Per SAE J1625 and ABYC E-11 |
| Mechanical Vibration | Per SAE J1455, 4G's 10-2K Hz |
| Voltage Breakdown | Per SAE J1625 500VAC |
| Salt Spray | Per SAE J1455, 96 hours |
| Weight | 150 grams max |

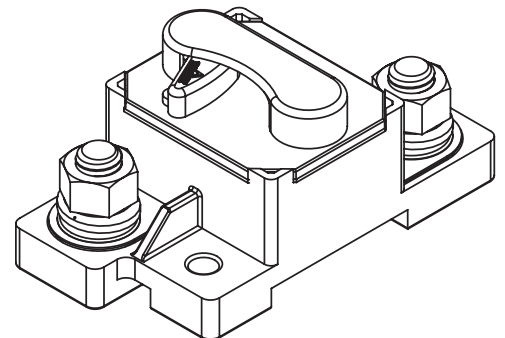

TRIP CURVE - Approximate Time, Current Characteristics At 77°F (25°C)

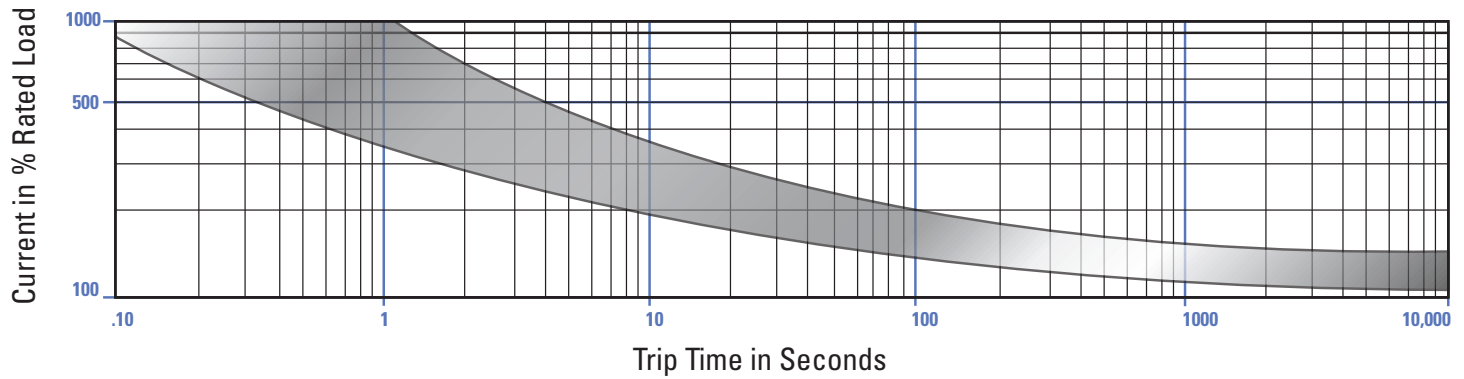

DIMENSIONS - FDLS

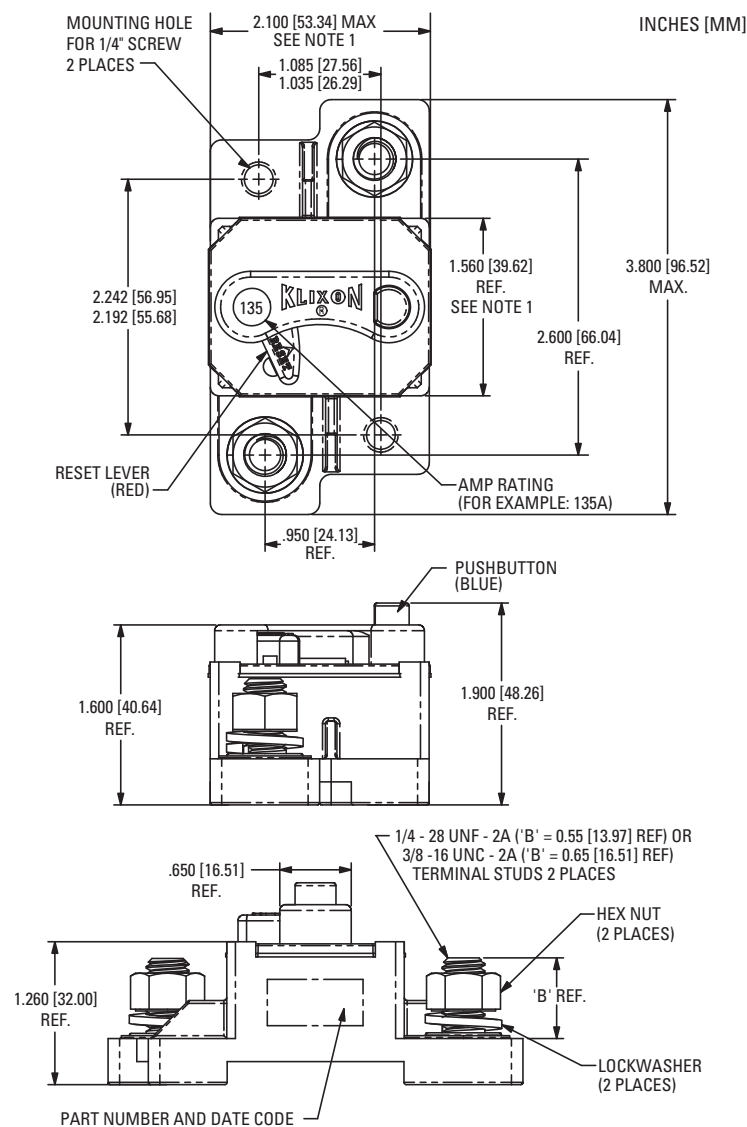

DERATING CURVE

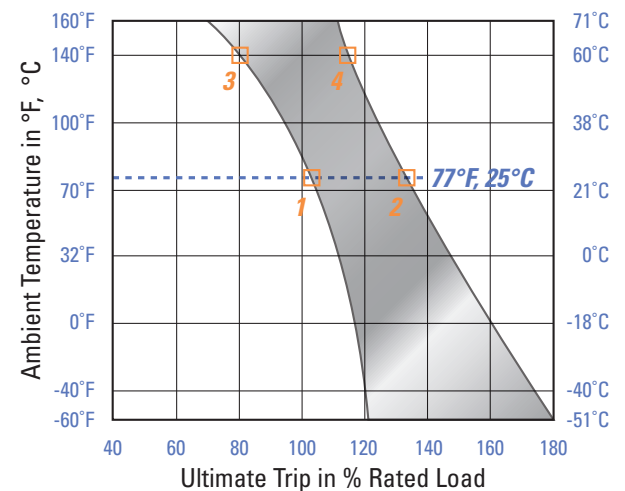

Performance characteristics are based on room temperature (77°F, 25°C). Consult Derating curve for ambient temperatures significantly higher or lower than standard room temperature.

Example: At 77°F (25°C) the device is calibrated to hold at 100% of rated current (1) and trip at 135% of rated current (2). At 140°F (60°C), the same device will hold at approximately 78% of rated current (3), and trip at approximately 115% of rated current (4).

Notes:

1. Dimension does not include sealing gasket.