

# ***ADVANCED ELECTRICAL PROTECTION***

## *Selection Guide*

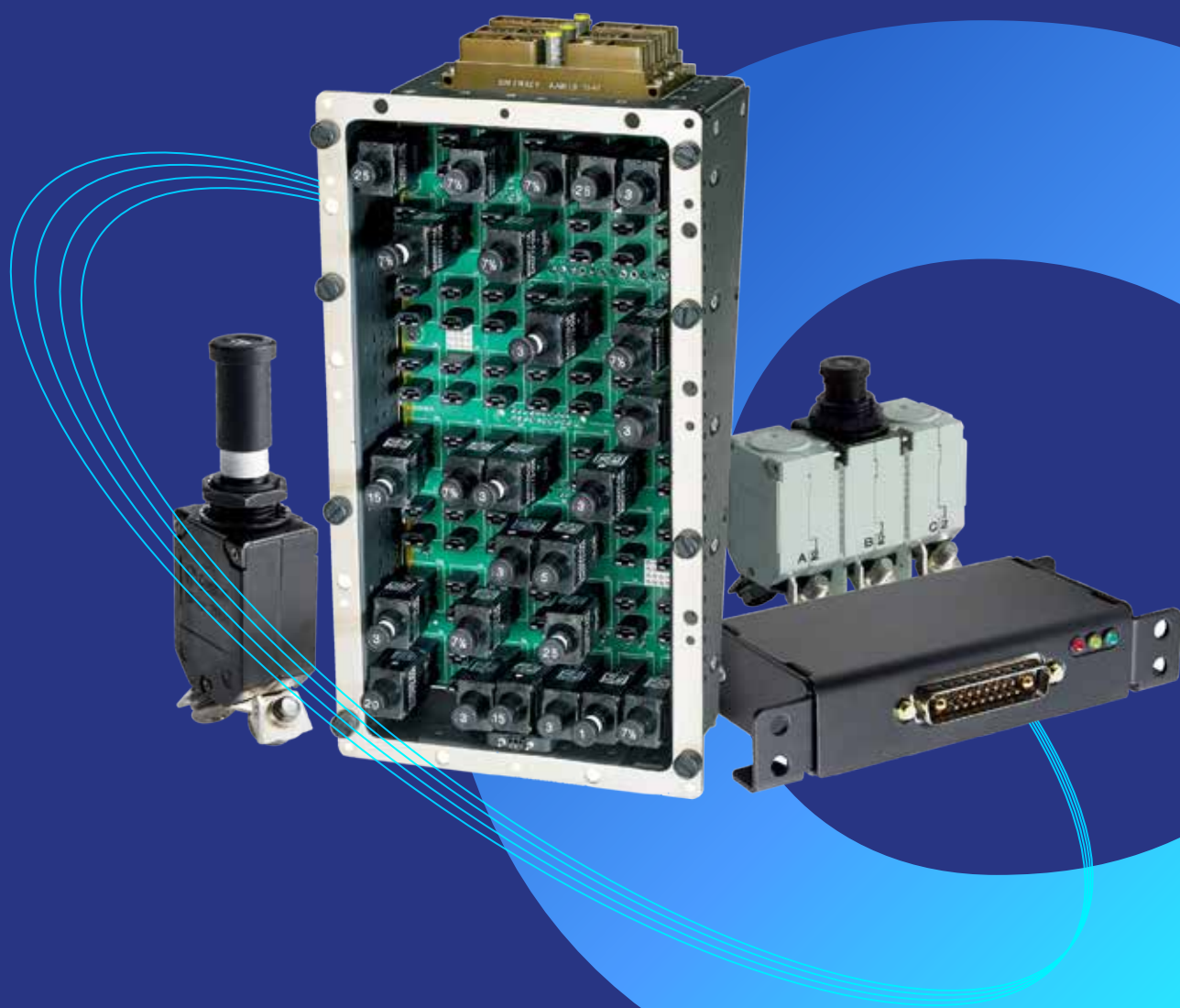

# ABOUT CROUZET

Crouzet is an independent company **manufacturing mechatronic components for demanding applications in Aerospace & Transportation, Energy, Building and Machinery Industry.**

Crouzet provides **Switches and Sensors, Electromechanical Actuators, Electrical Protection Equipment, Cockpit Controls, Automation Controllers and Relays, and Instrumentation Services.**

Since 1921, Crouzet has a heritage of close collaboration with customers in the development of products, from standard components to fully customized solutions.

Crouzet's customers and partners can rely on our teams worldwide to always meet and often exceed their expectations. Driven by innovation, our experts are focused on designing and delivering the right product for the right application.

Crouzet is your trusted partner of choice to face industrial challenges of today and tomorrow.

## WORLDWIDE PRESENCE



📍 HEADQUARTERS

■ SALES OFFICES

# CONTENTS

	Pages
Wire & structure & fuel tank protection _____	6
Wire & human & fuel tank protection _____	6
High Shock and Vibration Breakers _____	10
From SSCB to SSPC _____	10
Circuit Breaker panels _____	10
The «do it your self» kit _____	10
Remote Control Contactor & Circuit Breaker _____	10

## ELECTRICAL PROTECTION

Selection Guide (Choice by standard and ratings) _____	16
Small Model Circuit Breaker Single Pole _____	18
Small Model Circuit Breaker Three Pole _____	20
Big Model Circuit Breaker Single Pole _____	22
Big Model Circuit Breaker Three Pole _____	24
Frog legs Terminals _____	26
Push-pull Push-fit 6.35 mm Blade _____	28
Push-push & Flying Leads Version _____	30
GFCB & AFCB _____	32
Dummy & Watertight Push Button CB _____	34
Accessories _____	36

## ELECTRICAL DISTRIBUTION

Wire & load protection _____	37
Panel kit for Faston CB _____	38
RCCB 115/200 VAC 360-800 Hz _____	40

# WIRE PROTECTION

## HOW DOES IT WORK?

### ELECTROMECHANICAL CIRCUIT BREAKERS

In this type of Circuit Breaker, the current sensing is done by a bi-metal. The bi-metal is also part of the actuator that will open the line: the bi-metal is bent by heat coming from the current, the bi-metal moves the key lock, releases the latch and opens the line.

The Circuit Breaker bi-metal bends and releases the latch according to the overload current value and the overload duration (the bending is independant of the current direction).

If any, the auxiliary contact are galvanically isolated from the power and gives the state of the contacts (open or closed).

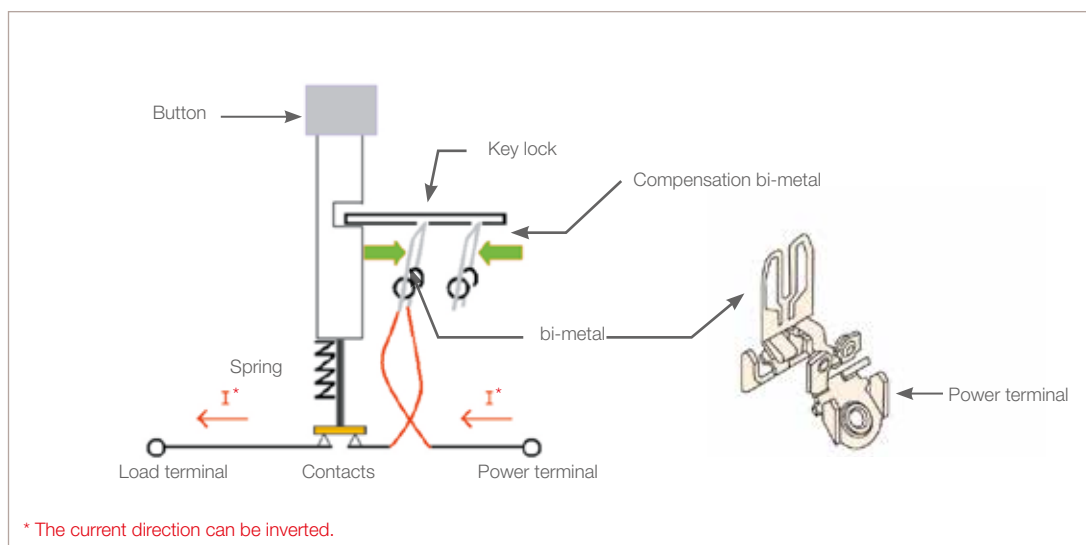

### «LIGHT, SIMPLE AND SAFE»

#### Light:

Our single phase EN2495 and MIL MS33201 V compliant model is the lightest in the world (<20 g with screws, washers and nut).

#### Simple:

- › Designed to be reused several times, spare components are not required
- › Can sometimes be used as a switch (within the defined endurance limits), they therefore perform a dual function of switching and protecting

#### Safe:

- › Our intrinsic fail safe\*\* and trip free\* conception enable a high level of safety (generally  $10^{-9}$  Flight Hours (FH) of not opening on a short circuit)
- › The temperature compensation ensures high performance over a wide temperature range (usually  $-60^{\circ}\text{C}$  to  $+125^{\circ}\text{C}$ )
- › Excellent resistance to mechanical stress
- › High current level peaks and high current flows tolerance

\* **Trip free**: even if the pushbutton is maintained in the closed position, the opening of the contacts (and therefore of the electric circuit) is ensured in the event of a current surge or short-circuit.

\*\* **Intrinsic safety (Fail safe)**: the Circuit Breaker has been designed with a fuse element to ensure that the electric circuit is opened in the extreme case of a blocked mechanism or glued contacts.



## SOLID STATE CIRCUIT BREAKERS (SSCB)

In this type of Circuit Breaker, the current sensing is done by a shunt or a Hall sensor in DC or a Current Transformer (CT) in AC. A microcontroller or FPGA acquires the current and simulates the  $i^2t$  curve, the switch function is often done by MOSFETS, bipolar transistors, SCR (i.e. thyristors).

The microcontroller will integrate the current going through the shunt and will open the MOSFET according to the current value and overload duration.

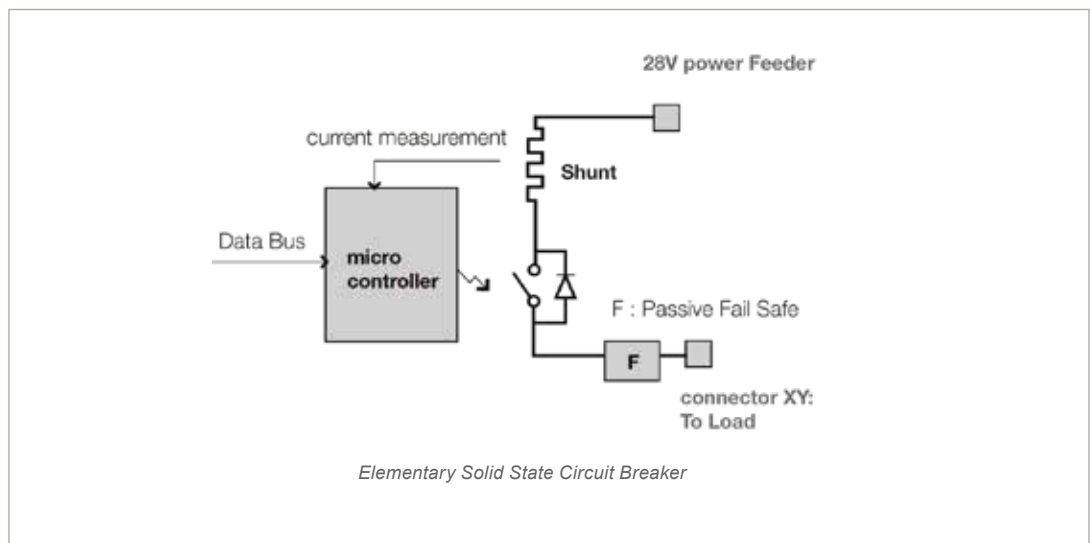

The patented fuse **F** gives a  $10^{-9}$  FH safety level (equivalent to mechanical Circuit Breakers) and still gives the possibility of reprogramming the Rated Current value by software.

### «MORE THAN A THERMAL SWITCH»

A SSCB is more than a thermal switch because when it is connected to a data bus, it provides intrinsically functions such as:

- › A remote switching ability (useful in application: contactor or relay function)
- › Dimmer or chopper function (useful in applications such as: motor speed control, light dimming, soft start)
- › Current monitoring (prognostic applications, load failure detection)

Also,

- › They are not susceptible to vibrations (useful in applications with high acceleration (Gs): aircraft, guns...)
- › They generate no audio noise (useful in applications such as: submarines, electric tanks, medical...)
- › The micro controller can run the arc fault protection algorithm
- › They can become a PLD with a protected power output (see p. 37)
- › They can protect the load (see p. 37).

# WIRE & STRUCTURE & FUEL TANK PROTECTION

## ARC FAULT DETECTION



Wet arc



Parallel arc

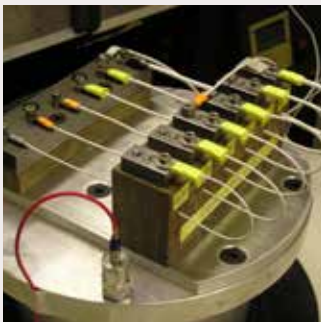

Series arc

### EWIS PROTECTION

The 14CFR Part 25 subpart H requirements asks aircraft OEM to consider the electrical wiring interconnection as a system. This means that the airworthiness of the wiring must be guaranteed for the complete lifetime of the aircraft.

AFCBs are a way to obtain compliancy to AC 25 1701-1.

The Advisory Circular (AC 251701-1) gives guidance for subpart H compliancy and indicates that a safety analysis of the Electric Wiring Interconnection Systems (**EWIS**) has to be done.

To certify the EWIS, the constructor must show a proactive approach to mitigate risks and perform a zonal analysis (EZAP).

When performing this analysis, it is very important to keep in mind that «**regardless of probability, any single arcing failure should be assumed for any power carrying line**» (page 31 of the AC) because the traditional way of thinking which was: «optional systems, like in flight entertainment, cannot cause a catastrophic failure condition» is not a valid assumption.

Locations where arcing must be mitigated:

- A** In flight entertainment area
- B** Cargo and baggage compartment door actuators
- C** Fuel tanks
- D** SWAMP area (Severe Wind And Moisture Problem area) such as wires in landing gear well or cockpit window heater or wing defrost heaters
- E** Galleys to protect electrical socket appliances such as: Cooktop ovens, waste compacting machines, coffee machines etc...
- F** Places where due to vibration, heat, aging or after an incorrect maintenance operation there is a risk of a power line touching:
  1. a critical hydraulic actuator line
  2. pressurized air line (air duct) or flight critical data line
  3. mechanical control system cable
  4. oxygen lines
  5. fuel lines
  6. water and water/waste line (and below them in case of dripping)
  7. hot air ducts

In case of an arc inside a bundle, arc fault technology will preclude a chain reaction in the bundle from inducing the loss of the complete bundle. Instead there will be a «controlled» deterioration of the wire(s) giving time for maintenance to be aware of the fault (by using the information coming from the circuit breaker) and thus avoiding a potential catastrophic situation.



Single pole AFCB

The algorithm in the electric board works faster than the thermal bi-metal function as shown on the adjacent chart.

### HOW DOES ARC FAULT PROTECTION WORK?

AFCBs combine the safety of standard Circuit Breakers and high accuracy electronics to mitigate arcing. Each standard thermal Circuit Breaker is equipped with an electronic board in order to analyze the current waveform in real time to detect if arcing is occurring.

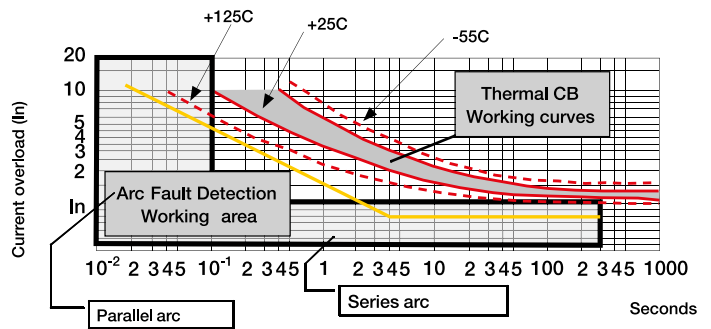

### ARC FAULT WILL CLEAR THE FAULT FASTER THAN THERMAL PROTECTION

In case of an electric hazard, the arcing energy (thus mechanical damage) is divided by a magnitude (generally 10) as shown in the adjacent chart.

The quick opening time of the GFCB-AFCB (generally 12 msec) will not release sufficient energy to puncture the conduit or the tank's skin (a pure thermal circuit breaker will open on an arc or a shorting current in 200 ms, thus 10 times slower which releases sufficient energy to puncture the tank's skin or conduit).

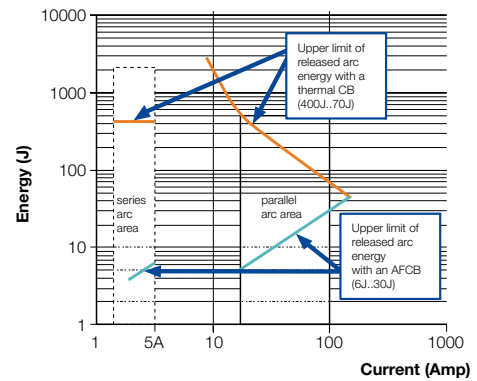

### CARBON COMPOSITE (CFRP) PROTECTION

Carbon Fibres Reinforced Polymer (CFRP) can be damaged (delamination) and can ignite in case of arcing. The use of arc fault protection will mitigate damage and risk significantly as illustrated below:

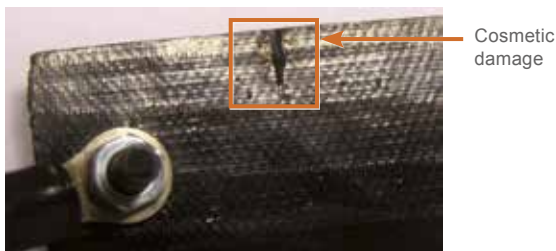

230 VAC Fault with arc fault protection: only cosmetic damages appears



230 VAC Fault without arc fault protection: delamination of the fibers

# WIRE & HUMAN & FUEL TANK PROTECTION

## GROUND FAULT CIRCUIT BREAKER (GFCB) WITH ARC FAULT

### FUEL TANK PROTECTION

Following SFAR88 recommendation, the FAA and EASA have compelled PART 25 aircrafts to protect fuel tanks with Ground Fault. The purpose of these Ground Fault protection device is to preclude fuel tank puncture by reducing drastically the amount energy liberated by a fault.

Documents **AC25981** and **AMC25981(a)** state that:

«any components located in or adjacent to a fuel tank must be qualified to meet standards that assure, during both normal and failure conditions, ignition of flammable fluid vapors will not occur».

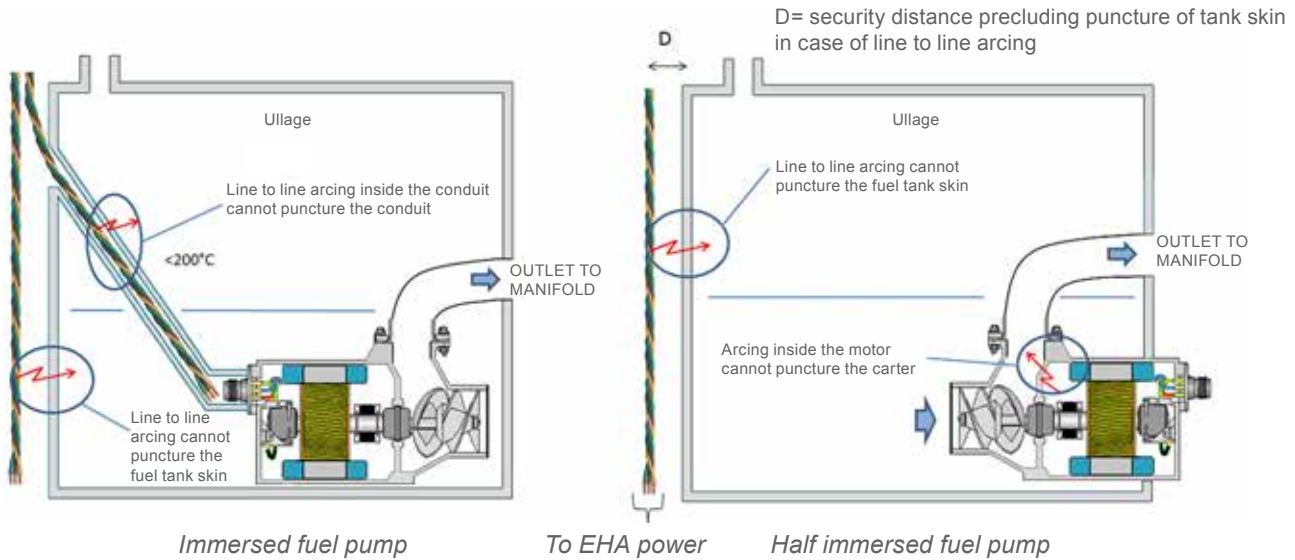

The reduction of damage concerns also:

- › Pylons & nacelles and small dimension aircraft where power line are routed near data buses or hydraulic tubes.
- › Wings where torque tube disconnections can cause severe damage to the wiring.
- › Composite wings with high power electric actuators (EHA, EBHA) in the vicinity of fuel tanks.

### THE GF-AFCB: A GFI CAPTURING LINE TO LINE ARCING

Traditional Ground Fault protection do not capture series arcing or line to line arcing because these two faults do not create a leakage current to the ground (i.e. the CT that measures the homopolar current will still read «zero» with one of these 2 faults occuring). By adding arc fault detection on each line, the GF-AFCB is a GFI and a circuit breaker that detects these 2 wire faults.

#### THE GF-AFCB STRUCTURE

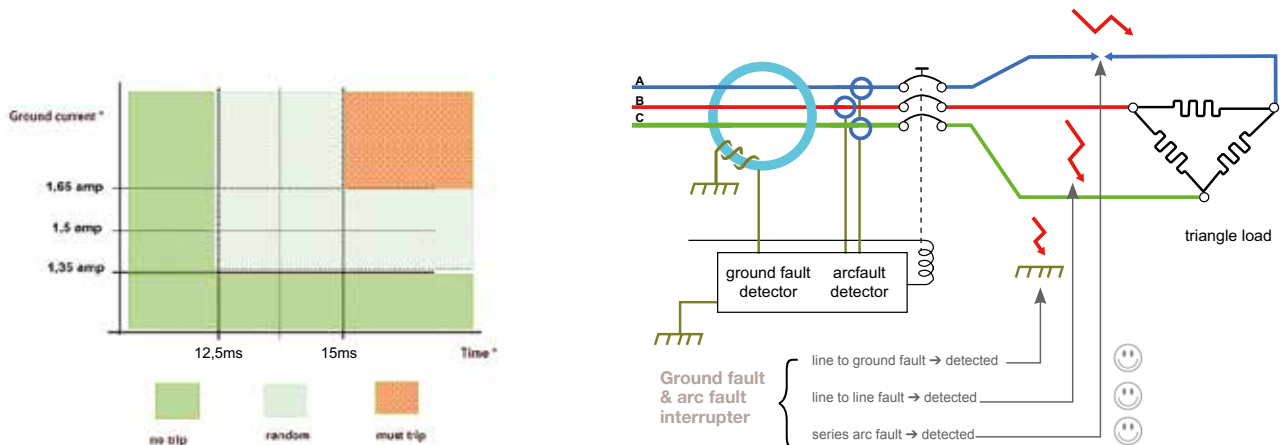

# ARC FAULT INTERRUPTER

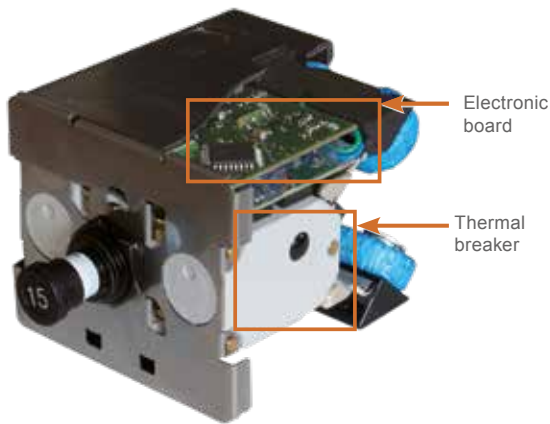

› The GF-AFCB has 2 thresholds:

- fault time confirmation
- maximum ground fault current.

This enables Crouzet to deliver products adapted to you load configuration. For example, the current threshold can be tuned either for a Delta (Triangle) motor or a Star (Wye) motor.

## HOW DOES IT WORK?

› Built in test

The GF-AFCB provides built-in test features that allow aircraft maintenance personal to verify that ground fault protection is functional, or that a ground fault has occurred: data issued from the led on the flat of the threaded barrel gives this information.

› Severed wire detection

The GF-AFCB includes «severed wire detection» (ie broken or cut wire) to preclude the heating of a motor if it is stalled (blocked) or running on only 2 phase (typical time detection is 1 second).

The above has been implemented because **AC25981 states page 9.3.1:**

( c ) «[...] Automatic protective means, such as arc/ground fault interrupters or other means, should be provided to shut down the pump when a single electrical phase failure occurs. Periodic inspections or maintenance of these features may be required».

**ON A «STAR» (WYE) LOAD, WITH GROUNDED CENTER, THE BEHAVIOR OF THE GFCB IS THE FOLLOWING**

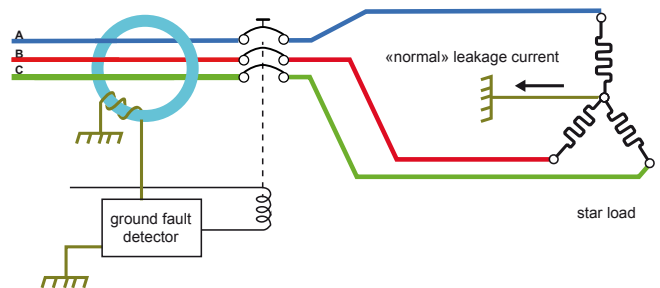
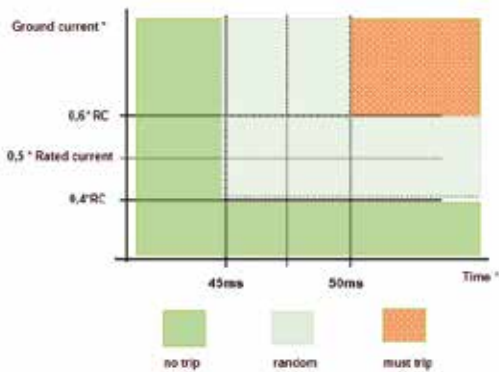

**TROUBLE SHOOTING THE WIRE WITH INFORMATION FROM THE BREAKER READER**

The following pictures are screenshots of the laptop running the breaker reader software after a fault has occurred.

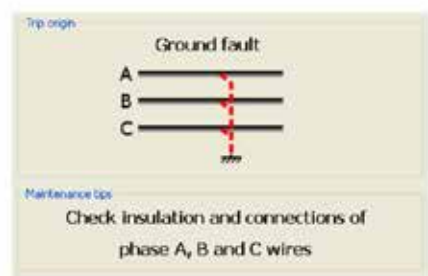
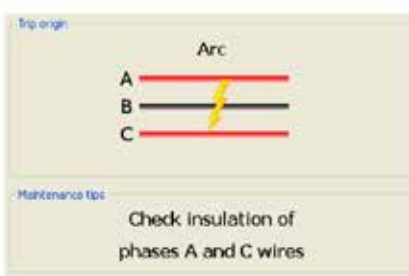
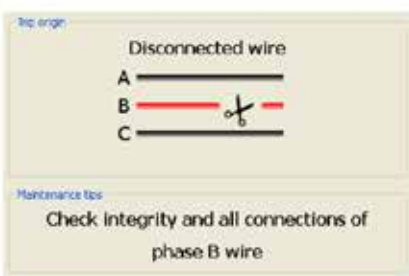



# ELECTRICAL PROTECTION

## HIGH SHOCK AND VIBRATION BREAKERS

Our High-Performance Thermal Circuit Breakers exceed the standard for shock and vibration for military applications.

It has always been troublesome for electrical systems engineers to find the best suitable circuit breakers for harsh environments. Crouzet has developed a specific series of circuit breakers which go far beyond the current standards.

When used in the vicinity of cannons or missile launchers and in circuit breaker panels installed next to machine guns (e.g. helicopters, jet fighters or armored vehicles) the high «shock and vibration» family avoids installing silent blocs on panels or on circuit breakers (while maintaining top circuit protection performance).

For the single pole circuit breaker the High Shock and Vibration products multiply by two the endurance level to random and sinus vibrations, compared to AS58091 level or basic MS33201 levels.

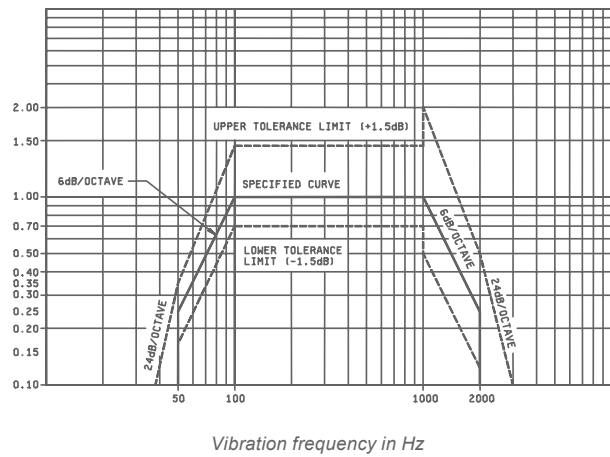
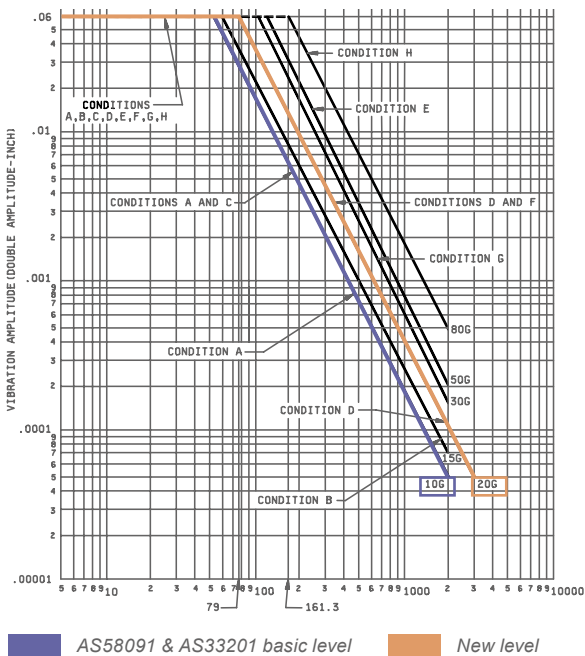

Test condition letter	Power spectral density	Overall rms G
A	.02	5.35
B	.04	7.56
C	.06	9.26
D	.1	11.95
E	.2	16.91
F	.3	20.71

Sinusoidal (MIL STD 202 method 204 D)	20 g-PK: condition D under 71 °C and RC
Random (MIL STD 202 method 214 A)	16.91 Grms: condition G under 71° C and RC
Shock (MIL STD 202 method 213B)	75 g 3 halvesine 6 msec: condition B



Typical circuit protection on following military platforms:

- › Fighter Aircraft
- › Military Helicopters
- › Ground Air Defense Systems
- › Military Land Tracked and Wheeled Vehicles
- › Missile Launchers
- › Naval Shipboard Applications

# ELECTRICAL DISTRIBUTION

## FROM SSCB TO SSPC

### FROM SSCB TO SSPC

Using the most recent solid state technology, Crouzet has developed 2 generic Solid State Circuit Breakers (SSCB): One for 28 VDC applications, the other for 115 VAC applications.

A Solid State Circuit Breaker is composed of a microcontroller, a switch and a data bus.

This enables a SSCB to provide more than just thermal protection; its role encompasses electrical functions such as: relay, gradator, chopper, ground fault, soft start, current measurement.

These functions can be used for light dimming, motor speed control, intermittent load command (on/off), inrush current limitation, sequential power ON of loads, load failure detection. This is why they become Solid State Power Controllers (SSPC).

### WHEN DO I NEED A SSPC?

Cost efficiency will depend on the ability to encompass several of the previous functions. When thinking of an SSPC solution the following chart must be kept in mind:

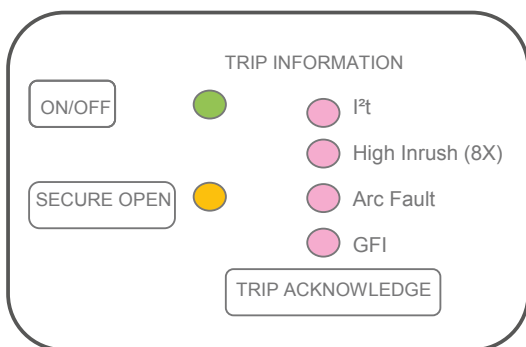
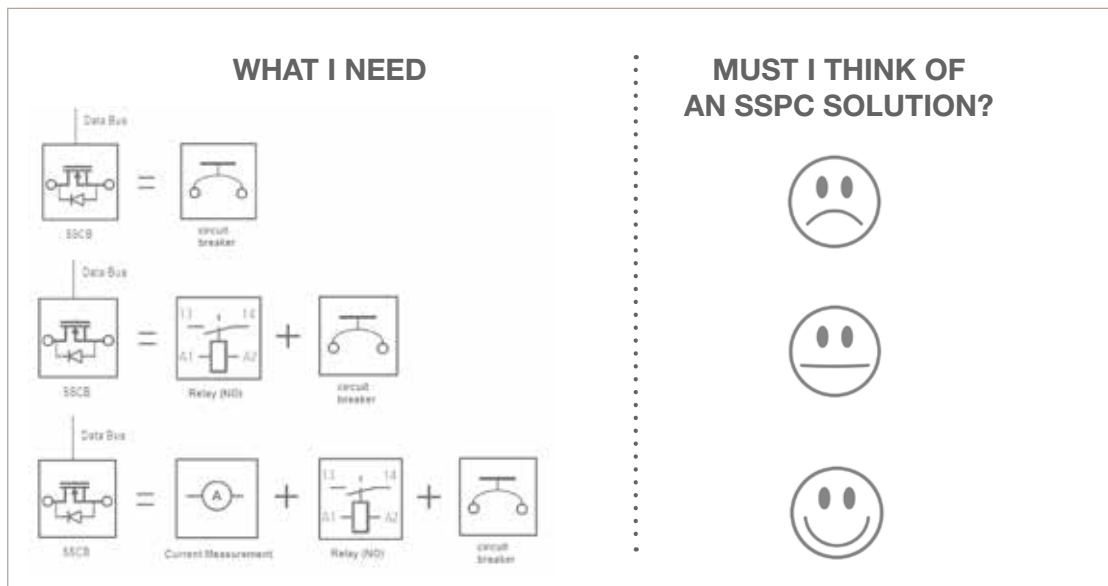

Laptop-tablet interface

### EASY TO OPERATE

Both 115 VAC and 28 VDC SSPC components are delivered with a laptop/tablet interface that enables a quick appropriation of SSPC features. Command from the laptop are transferred through CAN bus. The laptop/tablet interface can be replaced by a MCU or Utilities Management System (UMS) that sends and receives data frames through CAN2.0B.

The typical set of orders/queries is:

- ON/OFF** : Powers ON/OFF the load
- RESET** : RESETS the elementary switch after arc or thermal trip
- STATUS** : Asks for trip reason
- CURRENT** : Asks for current (A) value
- BACKUP** : Programs the behavior when data bus is disconnected



# ELECTRICAL DISTRIBUTION

## CIRCUIT BREAKER PANELS

### SUPPLIER OF CIRCUIT BREAKER PANELS ON SEVERAL JET AND HELICOPTER PROGRAMS

Crouzet has extensive experience in the design, development and production of illuminated and non-illuminated Circuit Breaker panels in Push/Pull or Push/Push versions, wire or PCB-FASTON version.



100 CB regional jet panel  
(wire + casing)

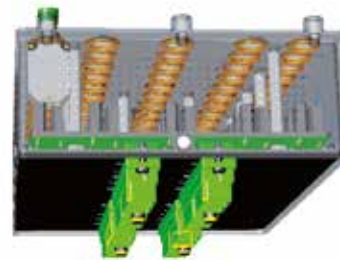

55 CB search and rescue helicopter panel  
(PCB + casing)

### OUR KNOW HOW

As a manufacturer of CB panels we will optimise your needs:

- › Geometry, connection and mounting as specified by your requirements and constraints
- › Customised marking of the front panel
- › Labelling of Circuit Breaker functions by engraving or easily-modified labels
- › Reduced weight due in part to our specially developed light weight Circuit Breaker and busbars
- › Expertise in mechanical and thermal limits (wire gauges, suitable sizes for Circuit Breakers, optimum distribution of Circuit Breaker, ...)
- › Expertise in busbars and connections with all the safety requirements (segregation, protection, ...)
- › ATP performed by automatic test benches

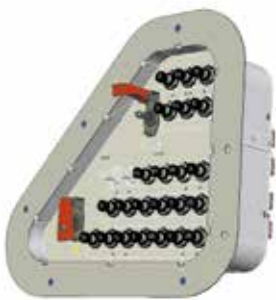

25 CB offshore helicopter panel  
(wire + casing)

### PREDICTABLE PANEL MASS FOR PANELS CONTAINING ONLY CBs



56 CB military helicopter panel  
(PCB + casing)

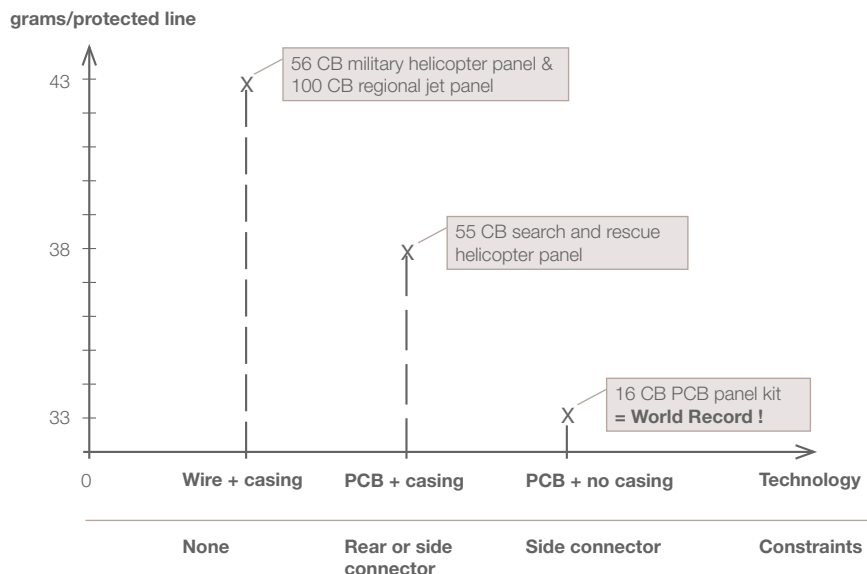

# ELECTRICAL DISTRIBUTION

## THE «DO IT YOUR SELF» KIT & BUS BARS

### THE KIT:

Crouzet is the first company to invent the concept of «do it yourself» Circuit Breaker panels and with this technique, it has created the **lightest extractible Circuit Breaker panel in the world!** The concept is based on a generic PWB carrying 16 Push Fit CBs that you can duplicate (if several bus bars are needed or if more Circuit Breakers are needed).



The «Do it your self» kit

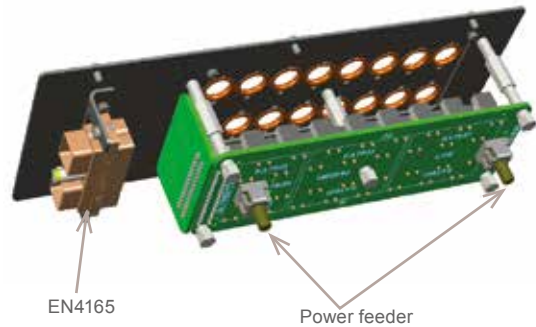

### KIT CONSTITUTION

The kit is composed of spacers, a PCB board, FASTON Circuit Breakers, and positioning rings. The front plate is compatible with accessories (Circuit Breaker gags and obturators).

### WORLD RECORD

The above kit assembly conveys 150 A at 71°C, it weighs 528 g with 16 Circuit Breakers and thus gives a panel efficiency ratio of 528 g=33g/CB → a world record!

### PREQUALIFICATION

To reduce development time the kit is qualified to harsh environment.

The use of the panel or its sub-sets enables the quick fielding of a qualified solution. If the assembly recommendation and Circuit Breaker locations are respected, Crouzet guarantees the electrical and vibrational behavior of the kit:

- › Temperature and electrically from -55°C to 71°C with a 100% utility factor (150 A output)
- › Vibrations: Random and Sinusoidal rays (Harsh Helicopter Level)
- › Crash, fungus, sand and dust.

### BUS BARS:

Traditional bus bar (rectangular)

Crouzet bus bar (flexible)

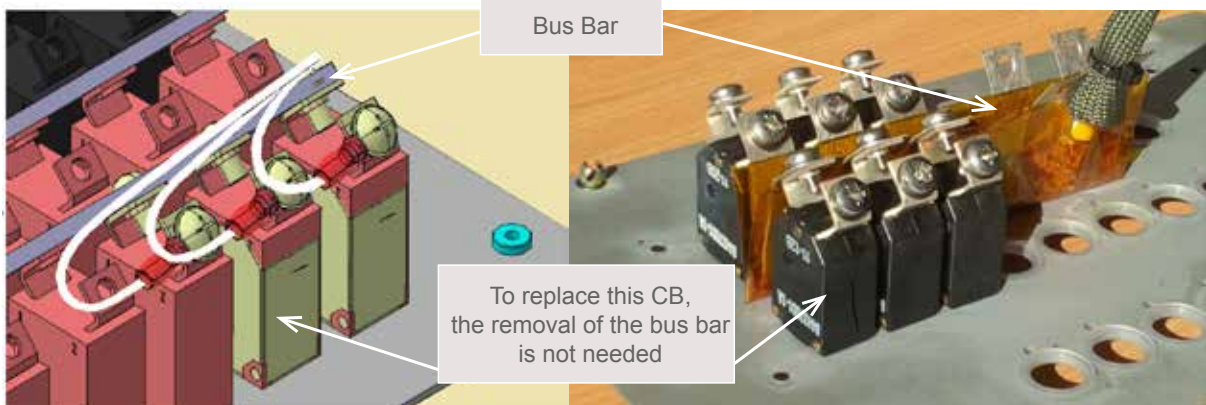

Use of frog legs CB (45° or 60°) is necessary

The flexible bus bar is compatible of many CB families

# ELECTRICAL DISTRIBUTION

## REMOTE CONTROL CONTACTOR & CIRCUIT BREAKER

The RCCB's primary use is to power loads that do not need to be permanently ON (to optimize energy). This is why it is used:

- › For powering hydraulic actuators of cargo bay doors
- › For powering Electro Hydraulic Actuators (EHA) and Electro Backup Hydraulic Actuators (EBHA)
- › For powering ON and OFF the galleys or In Flight Entertainment (IFE)

The RCCB contacts are CLOSED and OPENED (load is set ON and OFF) only once or twice during the flight; it is designed to commute at least 100,000 times, giving the aircraft a minimum of 50,000 cycles (take off and landing).

- › A unique feature: a mobile contact (in orange) that closes first and opens last ; this contact rich in tungsten endures rebound at closing time and arcing at opening time. The blue contact rich in silver ensures a low voltage drop during steady state operation ; this association guarantees 100 000 cycles under rated current with a power factor of 0.7.

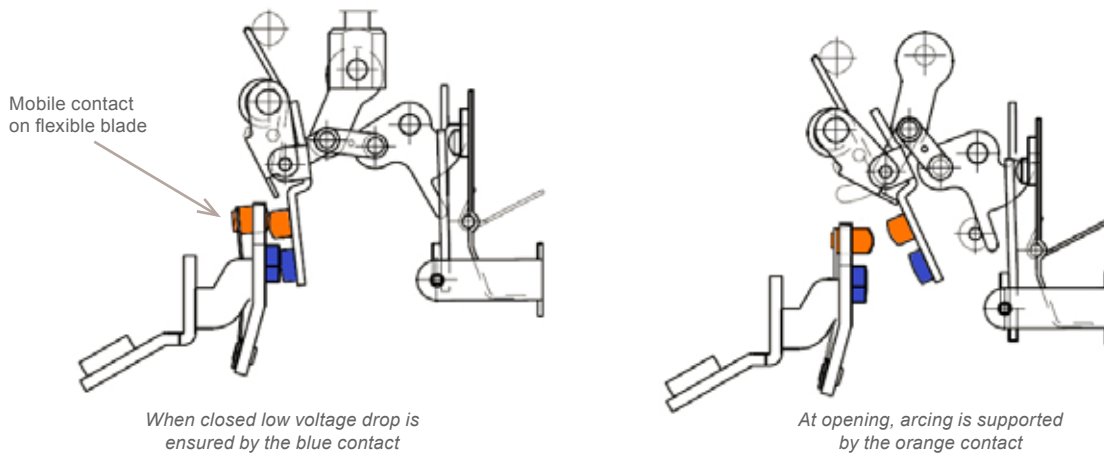

- › A unique feature: a signal contact withstanding «medium» current:

Using c1 b1 d1 «medium current signal contacts» it is possible to command 2 RCCBs with only one switch (here switch S1) :

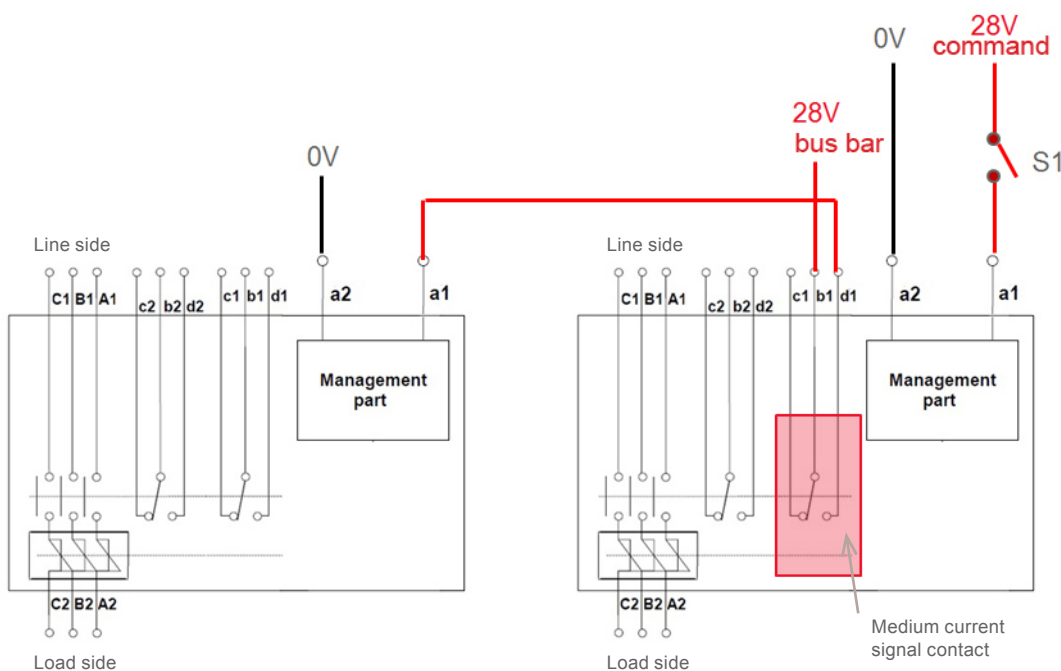

The RCCB merges a contactor function and a circuit breaker function in a single unit. The contactor is closed when 28 V is applied on the command input. The RCCB has a status display window and a mechanical «TRIP indicator».

When the CB has tripped, the mechanical «TRIP indicator» is «popped out» and must be pushed back in manually to RESET the circuit breaker.

Our real MTBF figure of 300,000 Flight Hours (field value) during 20 years of service have convinced our customers to mount the RCCB successively on:

- › Galleys feeders
- › Cargo doors actuation motors
- › Flight control power packs (EHA and EBHA) of primary flight control actuators (spoilers; ailerons; rudder)

Hereafter is an illustration of the main aircraft locations of the RCCB:

FIN	Design	Bus bar	P/N
12C	GALLEY	A	84 354 335
1X	BULK FAN HEATER	A	84 354 33 5
3	RECIRC FAN	B	84 354 350
3JV1	HYD PUMP	B	84 354 350
6XN1	L INDB ELEVATOR POWER SPLY	C	84 354 350
1XX	R INDB ELEVATOR POWER SPLY	C	84 354 350
3XX	GND SUPPLY	A	84 354 350
3XX1HG1	RECIRC FAN	A	84 354 350
51N	107XP (IFE)	A	84 354 360
1MC	L-MID AILERON POWER SPLY	A	84 354 350
3J2	L-MID AILERON POWER SPLY	A	84 354 350
3J1	HYD PUMP GND SUPPLY	A	84 354 360
3C2	HYD PUMP	B	84 354 350
1HG	Y UPPER RUDDER POWER SUPPLY	A	84 354 350
5X	G UPPER RUDDER POWER SUPPLY	B	84 354 350
23MC	L SPOILERS POWER SUPPLY	A	84 354 350
3MC	R SPOILERS POWER SUPPLY	B	84 354 350
24M	SLAT E-MOT POWER 1	A	84 354 350
6N2	SLAT E-MOT POWER 2	B	84 354 350
2X	212XP GND SUPPLY	C	84 354 350

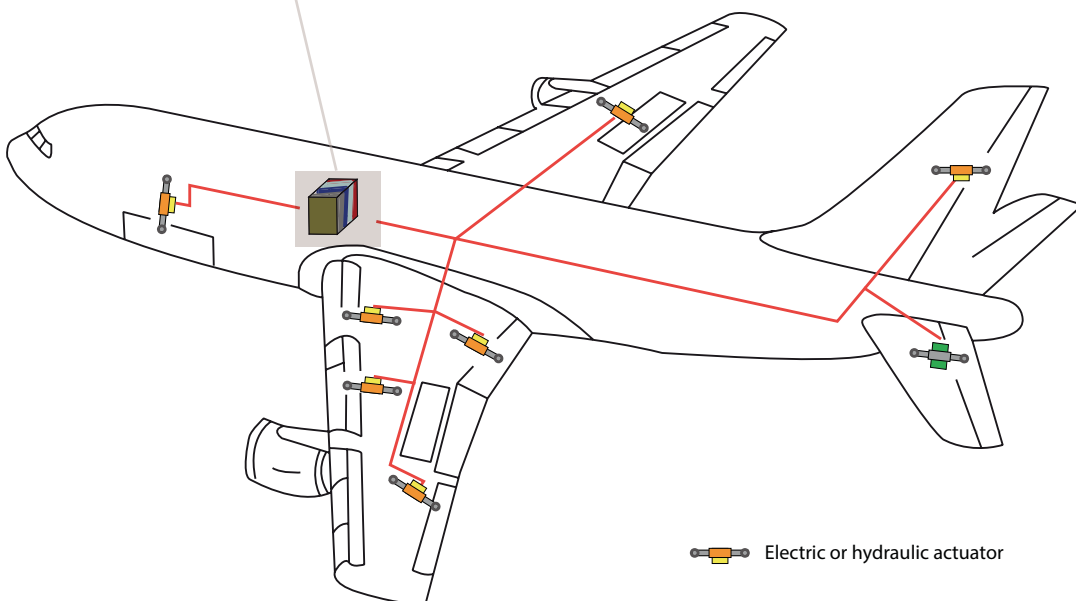
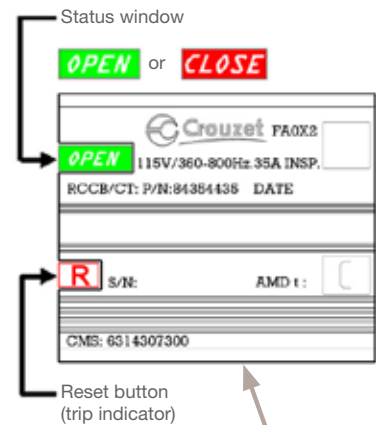

# SELECTION GUIDE

## CHOICE BY STANDARD AND RATING

Rate (A)	AS3320 AS33201 Alternate	AS3320 AS33201 QPL	AS3320-L AS33201-L Alternate	AS5692			AS14154 AS14154A Alternate	AS14154 AS14154A QPL	AS26574 Alternate	EN2495	
	DPMU	DPMU	DPMU	AFCB DPMT	GF-AFCB DPMT	AFCB DPMU	DMPT	DMPT	DPMU	Code M DMPU	Code U DPMU
	1	84 400 001	84 400 048	84 400 148				84 410 001	84 414 001	84 406 001	84 402 001
2	84 400 002	84 400 049	84 400 149				84 410 002	84 414 002	84 406 002	84 402 002	84 401 002
2.5	84 400 012	84 400 050	84 400 150				84 410 012	84 414 012	84 406 012	84 402 012	84 401 012
3	84 400 003	84 400 051	84 400 151	84 411 103	84 411 136	84 401 503	84 410 003	84 414 003	84 406 003	84 402 003	84 401 003
4		84 400 061	84 400 161								
5	84 400 005	84 400 052	84 400 152	84 411 105	84 411 137	84 401 505	84 410 005	84 414 005	84 406 005	84 402 005	84 401 005
6										84 402 006	
7.5	84 400 007	84 400 053	84 400 153	84 411 107	84 411 138	84 401 507	84 410 007	84 414 007	84 406 007	84 402 007	84 401 007
10	84 400 010	84 400 054	84 400 154	84 411 110	84 411 139	84 401 510	84 410 010	84 414 010	84 406 010	84 402 010	84 401 010
15	84 400 015	84 400 055	84 400 155	84 411 115	84 411 140	84 401 515	84 410 015	84 414 015	84 406 015	84 402 015	84 401 015
20	84 400 020	84 400 056	84 400 156	84 411 120	84 411 141	84 401 520	84 410 020	84 414 020	84 406 020	84 402 020	84 401 020
25	84 400 025	84 400 057	84 400 157	84 411 125	84 411 142	84 401 525	84 410 025	84 414 025	84 406 025	84 402 025	84 401 025
30	84 400 060	84 400 058	84 400 158						84 406 030		
Page	20	20	20	34	34	34	22	22	28	20	20

Rate (A)	EN2592		EN2665		EN2794		EN2995		EN2996		EN3661
	Code M DMPT	Code U DPMT	003 DGMT	004 DGMT	003 DGMU	004 DGMU	004 DPMU	005 DPMU	004 DPMT	005 DPMT	004 DGMU
	1	84 412 001	84 411 001					84 401 801	84 401 601	84 411 801	84 411 601
2	84 412 002	84 411 002					84 401 802	84 401 602	84 411 802	84 411 602	
2.5	84 412 012	84 411 012					84 401 812	84 401 612	84 411 812	84 411 612	
3	84 412 003	84 411 003					84 401 803	84 401 603	84 401 803	84 411 603	
4	84 412 004										
5	84 412 005	84 411 005					84 401 805	84 401 605	84 411 805	84 411 605	
7.5	84 412 007	84 411 007					84 401 807	84 401 607	84 411 807	84 411 607	
10	84 412 010	84 411 010					84 401 810	84 401 610	84 411 810	84 411 610	
15	84 412 015	84 411 015	84 313 015		84 306 015		84 401 815	84 401 615	84 411 815	84 411 615	
20	84 412 020	84 411 020	84 313 020	84 313 036	84 306 020	84 306 016	84 401 820	84 401 620	84 411 820	84 411 620	84 306 320
25	84 412 025	84 411 025	84 313 025	84 313 037	84 306 025	84 306 017	84 401 825	84 401 625	84 411 825	84 411 625	84 306 325
30					84 306 030		84 401 830	84 401 630			84 306 330
35			84 313 035	84 313 038	84 306 035	84 306 018					84 306 335
40			84 313 041		84 306 080						84 306 340
50			84 313 050	84 313 058	84 306 050	84 306 019					84 306 350
Page	22	22	26	26	24	24	20	20	22	22	24

Rate (A)	EN3661		EN3662			EN3773		EN3774			GAM TI-TII-40 / Air 6.625-403
	005 DGMU	006 DGMU	004 DGMT	005 DGMT	006 DGMT	004 DPMU	006 DPMU	003 DPMT	004 DPMT	006 DPMT	DPMU
	1						84 401 050	84 408 001	84 413 001	84 411 001	84 418 001
2						84 401 051	84 408 002	84 413 002	84 411 002	84 418 002	84 405 002
2.5						84 401 052	84 408 012	84 413 012	84 411 012	84 418 012	84 405 012
3						84 401 053	84 408 003	84 413 003	84 411 003	84 418 003	84 405 003
5						84 401 054	84 408 005	84 413 005	84 411 005	84 418 005	84 405 005
7.5						84 401 055	84 408 007	84 413 007	84 411 007	84 418 007	84 405 007
10						84 401 056	84 408 010	84 413 010	84 411 010	84 418 010	84 405 010
15						84 401 057	84 408 015	84 413 015	84 411 015	84 418 015	84 405 015
20	84 306 620	84 306 655	84 313 320	84 313 620	84 313 631	84 401 058	84 408 020	84 413 020	84 411 020	84 418 020	84 405 020
25	84 306 625	84 306 653	84 313 325	84 313 625	84 313 632	84 401 059	84 408 025	84 413 025	84 411 025	84 418 025	84 405 025
30	84 306 630		84 313 330	84 313 630							
35	84 306 635	84 306 654	84 313 335	84 313 635	84 313 633						
50	84 306 650	84 306 652	84 313 350	84 313 650	84 313 634						
Page	24	24	26	26	26	20	30	22	22	30	32

Rate (A)	LN29886 / LN29887	VG 95345-TEIL 6		VG 95345-TEIL 11		FROG LEGS - BUS BARS				extended trip	
		001 to 014 DPMU	101 to 114 DPMU	001 to 014 DPMU	101 to 114 DPMU	45° DMPU	60° DPMU	45° DPMT	60° DPMT	DGMU	DGMT
	1		84 402 001	84 402 801	84 412 001	84 412 801	84 437 001	84 437 201	84 417 001	84 417 201	
2		84 402 002	84 402 802	84 412 002	84 412 802	84 437 002	84 437 202	84 417 002	84 417 202		
2.5		84 402 012	84 402 812	84 412 012	84 412 812	84 437 012	84 437 212	84 417 012	84 417 212		
3		84 402 003	84 402 803	84 412 003	84 412 803	84 437 003	84 437 203	84 417 003	84 417 203		
4				84 412 004	84 412 804						
5	LN 29886 see EN2495 M	84 402 005	84 402 805	84 412 005	84 412 805	84 437 005	84 437 205	84 417 005	84 417 205		
6		84 402 006	84 402 806	84 412 006	84 412 806						
7.5		84 402 007	84 402 807	84 412 007	84 412 807	84 437 007	84 437 207	84 417 007	84 417 207		
10		84 402 010	84 402 810	84 412 010	84 412 810	84 437 010	84 437 210	84 417 010	84 417 210		
15		84 402 015	84 402 815	84 412 015	84 412 815	84 437 015	84 437 215	84 417 015	84 417 215		
20		84 402 020	84 402 820	84 412 020	84 412 820	84 437 020	84 437 220	84 417 020	84 417 220		84 313 820
25	LN29887 see EN2592 M	84 402 025	84 402 825	84 412 025	84 412 825	84 437 025	84 437 225	84 417 025	84 417 225	84 306 825	84 313 825
30		84 402 030	84 402 830	84 412 030		84 437 030	84 437 230	84 417 030	84 417 230	84 306 830	84 313 830
35										84 306 835	84 313 835
40										84 306 840	84 313 840
50										84 306 850	84 313 850
60										84 306 860	84 313 860
Page		20	20	22	22	28	28	28	28	24	26

**SIMULATOR CBs**

Rate (A)	Standard	Simulator	Standard	Simulator	Standard	Simulator	Standard	Simulator	Standard	Simulator
	EN3661-004 green button	same with black button	844006 green button	same with black button	844026 green button	same with black button	844006 green button	same with black button rotated 180°	EN2495-M 0.5 A Rating	same with different button value
	DGMU	DGMU	DPMU	DPMU	DPMU	DPMU	DPMU	DPMU	DPMU	DPMU
0.5			84400611	84400650			84400611	84400636	84402011	
0.75								84400637		
1			84400601	84400651			84400601	84400638		
1.5				84400652				84400639		
2								84400640		
2.5			84400612		84402612	84402712	84400612	84400641		
3			84400603	84400653	84402603	84402703	84400603	84400642		84402036
4			84400604	84400654			84400604	84400643		
5			84400605	84400655	84402605	84402705	84400605	84400644		84402037
7.5			84400607	84400656	84402607	84402707	84400607	84400645		84402038
10			84400610	84400657	84402610	84402710	84400610	84400646		84402039
15			84400615	84400658	84402615	84402715	84400615	84400647		84402040
20			84400620	84400659	84402620	84402720	84400620	84400648		84402041
25	84306325	84306353	84400625	84400661	84402625	84402725	84400625	84400649		84402042
30			84400630	84400662						
35	84306335	84306352								84402043
50	84306350	84306351								
no marking										84402044
mounting hw	mounting hardware on CB		mounting hardware in bag		mounting hardware on CB		mounting hardware on CB		mounting hardware on CB	

**ATTACHEMENT HARDWARE CODIFICATION**

Delivery hardware code	Connection and attachment hardware kits EN 6113	Delivery conditions	
	Kit part No. <sup>a</sup>	Fitted	Supplied separately
A	EN 6113A1	-	X
B	EN 6113B1	-	X
C	Without connection and attachment hardware kits		
D	EN 6113A1	X	-
E	EN 6113B1	X	-

<sup>a</sup> Spare parts could be ordered separately, information see EN 6113.

*Hardware code*

Kit part-no.	Components of the hardware kits		
	Single part-no. <sup>a</sup>	Description	Pieces per kit
EN 6113A	EN 6113CS08-01	Connecting screw	2
	EN 6113CW04	Connecting lockwasher	2
	EN 6113AN01	Attachment nut	1
	EN 6113AW01	Attachment lockwasher	1
EN 6113B	EN 6113AN01	Attachment nut	1
	EN 6113AW01	Attachment lockwasher	1
EN 6113C	EN 6113CS08-01	Connecting screw	6
	EN 6113CW04	Connecting lockwasher	6
	EN 6113AN01	Attachment nut	1
	EN 6113AW01	Attachment lockwasher	1
EN 6113A1	EN 6113CS08-01	Connecting screw	2
	EN 6113CW04	Connecting lockwasher	2
	EN 6113AN02	Attachment nut	1
	EN 6113AW01	Attachment lockwasher	1
EN 6113B1	EN 6113AN02	Attachment nut	1
	EN 6113AW01	Attachment lockwasher	1
EN 6113C1	EN 6113CS08-01	Connecting screw	6
	EN 6113CW04	Connecting lockwasher	6
	EN 6113AN02	Attachment nut	1
	EN 6113AW01	Attachment lockwasher	1

<sup>a</sup> Spare parts can be ordered separately

*Hardware kit part*



# SMALL MODEL CIRCUIT BREAKER SINGLE POLE

## DPMU



### REFERENCES

Rating	No signal contact							Non polarised / polarised signal contact		
1 A	84 400 001	84 400 048/148	84 402 001	84 400 248	84 401 001	84 401 050	84 440 001	84 400 801/601	84 401 801/601	84 402 801/601
2 A	84 400 002	84 400 049/149	84 402 002	84 400 249	84 401 002	84 401 051	84 440 002	84 400 802/602	84 401 802/602	84 402 802/602
2.5 A	84 400 012	84 400 050/150	84 402 012	84 400 250	84 401 012	84 401 052	84 440 012	84 400 812/612	84 401 812/612	84 402 812/612
3 A	84 400 003	84 400 051/151	84 402 003	84 400 251	84 401 003	84 401 053	84 440 003	84 400 803/603	84 401 803/603	84 402 803/603
4 A		84 400 061/161		84 400 261						
5 A	84 400 005	84 400 052/152	84 402 005	84 400 252	84 401 005	84 401 054	84 440 005	84 400 805/605	84 401 805/605	84 402 805/605
6 A			84 402 006							84 402 806/606
7.5 A	84 400 007	84 400 053/153	84 402 007	84 400 253	84 401 007	84 401 055	84 440 007	84 400 807/607	84 401 807/607	84 402 807/607
10 A	84 400 010	84 400 054/154	84 402 010	84 400 254	84 401 010	84 401 056	84 440 010	84 400 810/610	84 401 810/610	84 402 810/610
15 A	84 400 015	84 400 055/155	84 402 015	84 400 255	84 401 015	84 401 057	84 440 015	84 400 815/615	84 401 815/615	84 402 815/615
20 A	84 400 020	84 400 056/156	84 402 020	84 400 256	84 401 020	84 401 058	84 440 020	84 400 820/620	84 401 820/620	84 402 820/620
25 A	84 400 025	84 400 057	84 402 025	84 400 225	84 401 025	84 401 059	84 440 025	84 400 825/625	84 401 825/625	84 402 825/625
30 A	84 400 060	84 400 058	84 402 030	84 400 230			84 440 030	84 400 860/660	84 401 830/630	84 402 830/630

Ratings 0.5; 0.75; 1.5 A are available.

Mounting hardware		HV												
Threaded barrel	M12-0.75 M12-100 7/16													
Terminal Screw	8-32 UNC M4													
Terminal		Offset	Offset	Offset	Offset	Aligned	Aligned	Aligned	Offset	Aligned	Offset			

Button		HV												
Green color														
Black color														
Long neck option														

Conformity standard		HV												
EN 2495				M		U								
EN 2995												004/005		
EN 3773								004						
AS33201 - MS3320														
VG 95345 TEIL 6														
BACC 18Z&18AD like														

Mass / MTBF / Vibration / Technical file		HV													
Mass without mounting hardware (g)	< 18	< 18	< 18	< 18	< 18	< 18	< 18	< 20					< 20		
Mass with mounting hardware (g)	< 21	< 20	< 20	< 20	< 20	< 20	< 20	< 22					< 22		
MTBF FH (Typical)	> 7.2 M	> 7.2 M	> 7.2 M	> 7.2 M	> 7.2 M	> 7.2 M	> 7.2 M	> 7.2 M					> 3.6 M		
Vibrations, for detail see below	MIL	MIL	VG		HV	EN		EN	EN				EN	EN	VG
Technical File		SP4374/9944			SP9930			SP4356							

### GENERAL CHARACTERISTICS

Electrical		HV												
Breaking current 1co + 2OCO	28 VDC 6000 A													115 VAC 60 Hz-230 VAC 50 Hz
Dielectric	1500 V													CONTACT CROUZET
Endurance cycles	5000 (with L/R: 5 ms)													
Insulation resistance	above 100 MΩ													
Working life (endurance) at 5x RC	50 cycles													
Auxiliary contact current	0.1..0.2 A													
Voltage drop compliance	EN2495/2995/MS3320/AS33201													

Mechanical		HV												
Operating force	3,5N< push<45N / 5N<pull<30N													
Endurance	without load: 5000 cycles    resistive load: 2500 cycles													
Tightening torque	barrel nut: recommended: 4 ± 0.25 N.m maximum : 5.0 N.m    terminal screw: recommended: 1.6 ± 0.1 N.m maximum : 2.0 N.m													

Environmental		HV												
Salt spray	48h 5% NaCl													
Humidity: Test b	RTCA DO160 10 cycles													
Operating temperature	-60°C +125°C for all ratings except 30 A: - 60°C + 90°C													
Acceleration (centrifugal)	17 g													
Vibrations	EN (at 70°C)					MIL & VG (at 71°C)							MIL (High Vibrations)	
Sinusoidal (80..2000 Hz)	10 g-PK and 5g-PK after 500Hz at 90% of RC					10 g-PK at 100 % of RC and 15 g-PK at 0% of RC							20 g-PK at 90% of RC	
Random (10.. 2000 Hz)	5.82 Grms at 90% of RC					9.26 Grms at 100 % of RC							16.9 Grms at 90 % of RC	
Shock	50 g halfsine 11 msec 6 directions					50 g halfsine 11 msec 6 directions							75 g halfsine 6 msec 6 directions	



**CURVES**

**Trip times envelope for temperature from -55°C to 125°C (direct overload)**

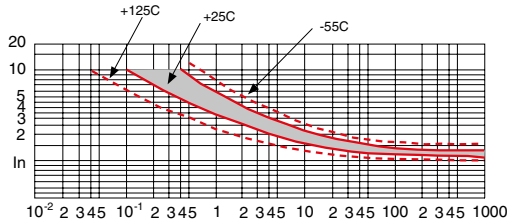

**Maximum and minimum limit of ultimate trip**

Rating	1.5 → 5 A	7.5 → 25 A
Non tripping point at 25°C	1.15 * RC	1.15 * RC
Tripping point at 25°C	1.4 * RC	1.4 * RC
Tripping time at 2 * RC	2 s → 15 s	4 s → 20 s
Non tripping point at 125°C	1 * RC	1 * RC

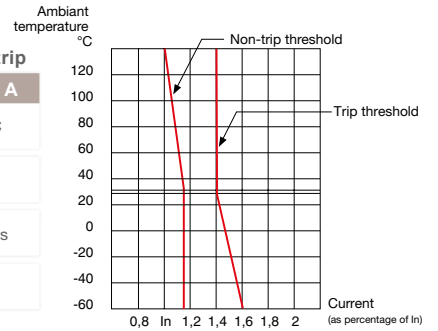

**DIMENSIONS**

84 400 0  
84 402 0

84 400 6-8  
84 402 6-8

84 401 0

84 401 6-8

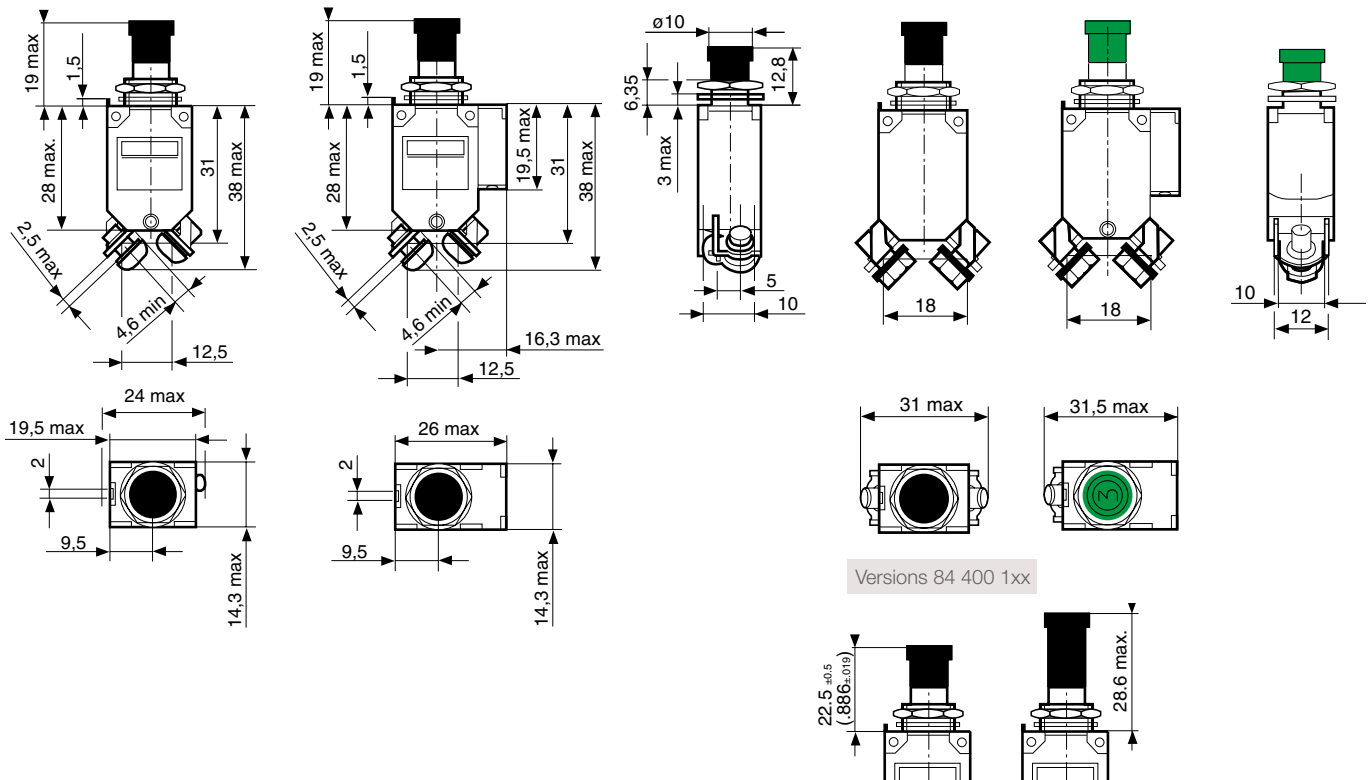

**PANEL CUTOUT RECOMMENDATION**

› Thickness: 1.6 mm → 3 mm

Versions 84 400 0

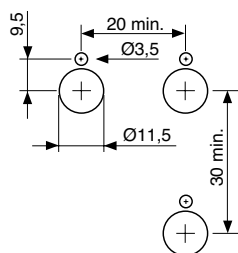

Versions 84 402 0

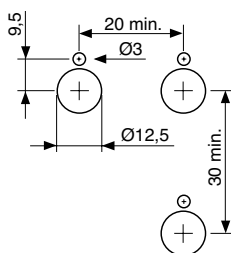

Versions 84 401 0 - 6 - 8



# SMALL MODEL CIRCUIT BREAKER THREE POLE DPMT



## REFERENCES

Rating	No signal contact						Non polarised/polarised signal contact		
1 A	84 410 001	84 411 001	84 412 001	84 413 001	84 414 001	84 450 001	84 410 801/601	84 411 801/601	84 412 801/601
2 A	84 410 002	84 411 002	84 412 002	84 413 002	84 414 002	84 450 002	84 410 802/602	84 411 802/602	84 412 802/602
2.5 A	84 410 012	84 411 012	84 412 012	84 413 012	84 414 012	84 450 012	84 410 812/612	84 411 812/612	84 412 812/612
3 A	84 410 003	84 411 003	84 412 003	84 413 003	84 414 003	84 450 003	84 410 803/603	84 411 803/603	84 412 803/603
4 A			84 412 004						84 412 804/604
5 A	84 410 005	84 411 005	84 412 005	84 413 005	84 414 005	84 450 005	84 410 805/605	84 411 805/605	84 412 805/605
6 A			84 412 006						84 412 806/606
7.5 A	84 410 007	84 411 007	84 412 007	84 413 007	84 414 007	84 450 007	84 410 807/607	84 411 807/607	84 412 807/607
10 A	84 410 010	84 411 010	84 412 010	84 413 010	84 414 010	84 450 010	84 410 810/610	84 411 810/610	84 412 810/610
15 A	84 410 015	84 411 015	84 412 015	84 413 015	84 414 015	84 450 015	84 410 815/615	84 411 815/615	84 412 815/615
20 A	84 410 020	84 411 020	84 412 020	84 413 020	84 414 020	84 450 020	84 410 820/620	84 411 820/620	84 412 820/620
25 A	84 410 025	84 411 025	84 412 025	84 413 025	84 414 025	84 450 025	84 410 825/625	84 411 825/625	84 412 825/625
30 A			84 412 030	84 413 030		84 450 030			

## Mounting hardware

Threaded barrel	M12-0.75 M12-100 7/16		●	●	●	●			●	●
Terminal Screw	8-32 UNC M4	●	●	●	●	●	●	●	●	●
Terminal		Offset	Offset	Offset	Offset	Offset	Aligned	Offset	Offset	Offset

## Button

Green color								●	●	●
Black color	●	●	●	●	●					
Long neck										

## Conformity standard

EN 2592		U	M							
EN 3774		004		003						
EN 2996								004/005		
VG 95345 TEIL 11			●							●
AS 14154B/MS14154	●					QPL				
BACC 18AC&18AE like							●			

## Mass / MTBF / Vibration / Technical file

Mass without mounting hardware (g)										< 51
Mass with mounting hardware (g)										< 60
MTBF FH (Typical)										> 700000
Vibration, for detail see below	MIL	EN	VG	EN	MIL	EN		EN	EN	EN
Technical File	-	-	-	-	-	-		-	-	-

## GENERAL CHARACTERISTICS

Electrical		
Breaking current 1CO + 2OCO	115/200 VAC (400 Hz)	115/200 VAC 60 Hz-230/400 VAC 50 Hz
Dielectric	2000 A	
Endurance (electrical overloads)	1500 V	
Insulation resistance	5000 (with cos fi: 0.7)	
Working life (endurance) at 5xRC	above 100 MΩ	CONTACT CROUZET
Auxiliary contact current	50 cycles	
Voltage drop compliance	0.1..0.2 A	
	MS14154/AS14154A/EN2592/2996/3774	

Mechanical	
Operating force	8N<push<80N / 5N<pull<30N
Endurance (manual open/close)	no load / 5000 cycles on resistive load / 5000 cycles
Tightening torque	barrel nut: recommended: 4 ± 0.25 N.m maximum : 5.0 N.m terminal screw: recommended: 1.6 ± 0.1 N.m maximum : 2.0 N.m

Environmental	
Salt spray	48h 5% NaCl
Humidity: Test b	RTCA DO160 10 cycles
Operating temperature	-60°C +125°C for all ratings except 30 A: - 60°C + 90°C
Acceleration (centrifugal)	17 g
Vibrations	EN (at 70°C) MIL & VG (at 71°C)
Sinusoidal (80..2000 Hz)	10 g-PK and 5g-PK after 500Hz at 90 % of RC 10 g-PK at 100% of RC & 15 g-PK at 0% of RC
Random (10.. 2000 Hz)	5.82 Grms at 90 % of RC 9.26 Grms at 100 % of RC
Shock	50 g halfsine 11 msec 6 directions 50 g halfsine 11 msec 6 directions

**CURVES**

**Trip times envelope for temperature from -55°C to 125°C (direct overload)**

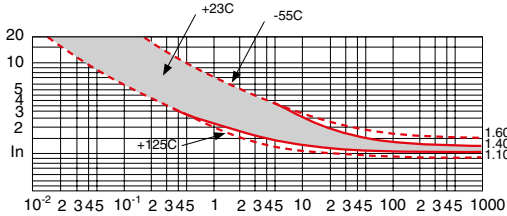

**Maximum and minimum limit of ultimate trip**

Rating	1.5 → 5 A	7.5 → 25 A
Non tripping point at 25°C	1.15 * RC	1.15 * RC
Tripping point at 25°C	1.4 * RC	1.4 * RC
Tripping time at 2 * RC	2 s → 15 s	4 s → 20 s
Non tripping point at 125°C	1 * RC	1 * RC

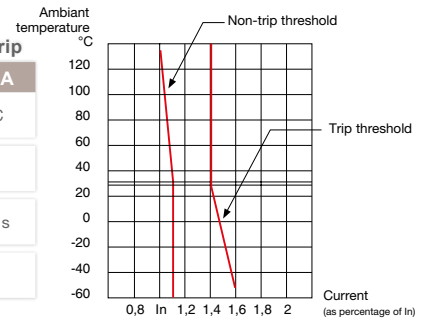

**DIMENSIONS**

84 411 0    84 412 0  
84 413 0    84 414 0

84 411 6    84 411 8  
84 412 8    84 413 6

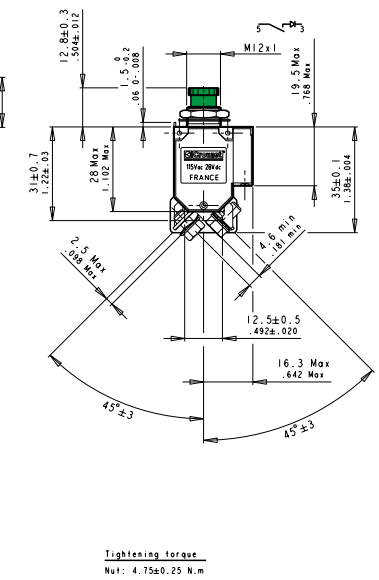
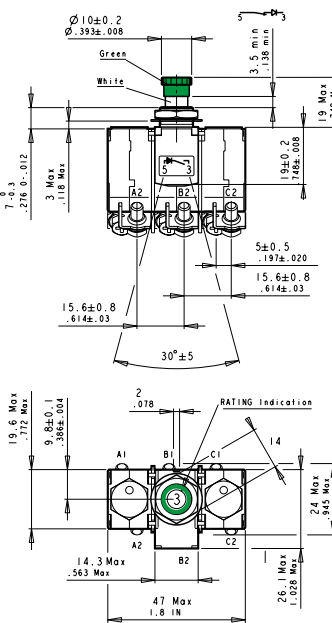
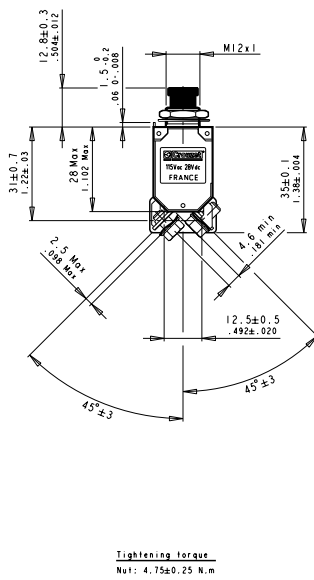
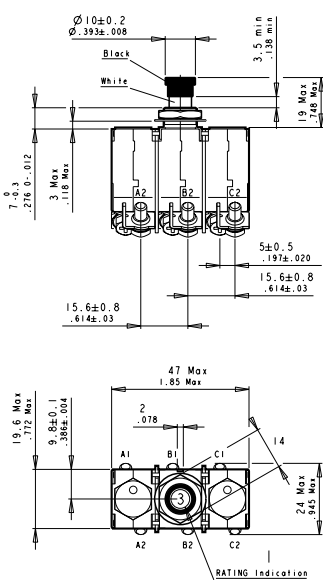

**Tightening torque**  
Nut: 4.75±0.25 N.m  
Screw: 1.7±0.1 N.m

**Tightening torque**  
Nut: 4.75±0.25 N.m  
Screw: 1.7±0.1 N.m

**PANEL CUTOUT RECOMMENDATION**

› Thickness: 1.6 mm → 3 mm

84 411 0    84 412 0  
84 413 0

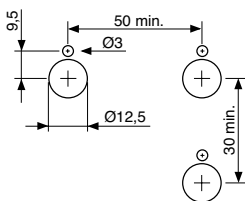

84 414 0

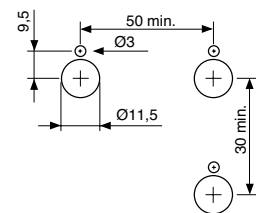

84 411 6    84 411 8  
84 412 8    84 413 6

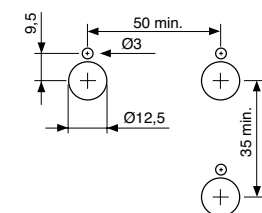

# BIG MODEL CIRCUIT BREAKER SINGLE POLE

## DGMU



### REFERENCES

Rating	No signal contact		No signal contact long trip time	Non polarised/polarised signal contact		Polarised signal contact
15 A	84 306 015					
20 A	84 306 020	84 306 016		84 306 320/620	84 306 316/616	84 306 645/655
25 A	84 306 025	84 306 017	84 306 825	84 306 325/625	84 306 317/617	84 306 643/653
30 A	84 306 030		84 306 830	84 306 330/630		
35 A	84 306 035	84 306 018	84 306 835	84 306 335/635	84 306 318/618	84 306 644/654
40 A	84 306 080		84 306 840	84 306 340/640		
50 A	84 306 050	84 306 019	84 306 850	84 306 350/650	84 306 319/619	84 306 642/652
60 A			84 306 860		84 306 321/621	

Mounting hardware							
Threaded barrel	M12-0.75		●				
	M12-100						
	7/16						
Terminal Screw	8-32 UNC		●			●	●
	M4	●		●			
Hole ø5.5 for Bus-Bar & 40° angle							●

Button							
Green color					●	●	●
Black color		●	●	●			

Conformity standard							
EN 2794		003	004				
EN 3661					004/005	004/005	006
BACC 18R&18X like				●			

Mass / MTBF / Vibration / Technical file							
Mass without mounting hardware (g)			61		61		66
Mass with mounting hardware (g)			65		65		70
MTBF FH (Typical)			> 10 M		> 10 M		> 6 M
MIL vibration condition Sinus/Random			A & C		A & C		A & C
Technical File		-	SP4393	-	-	SP4339	SP9300

### GENERAL CHARACTERISTICS

Electrical					
		28 VDC		115 VAC (400 Hz)	115 VAC 60 Hz-230 VAC 50Hz
Breaking current 1co + 2OCO		4000 A ; 2000 A long trip		2000 A ; 1500 A long trip	CONTACT CROUZET
Dielectric		1500 V		1500 V	
Endurance (electric overloads)		5000 (with L/R: 5 ms)		5000 (with cos fi: 0.7)	
Insulation resistance		above 100 MΩ		above 100 MΩ	
Working life (endurance) at 5xRC		50 cycles		50 cycles	
Voltage drop compliance		EN2794/3661		EN2794/3661	

Mechanical				
Operating force		3,5N<push<55N / 5N<pull<40N		
Endurance (manual open/close)		no load : 5 000 cycles on resistive load : 2 500 cycles		
Tightening torque		barrel nut: recommended: 4 ± 0.25 N.m maximum : 5.5 N.m    terminal screw: recommended: 2.35 ± 0.15 N.m maximum : 2.5 N.m		

Environmental			
Salt spray		48h / 5% NaCl	
Humidity: Test b		RTCA DO160 / 10 cycles	
Operating temperature		-60°C +125°C	
Acceleration (centrifugal)		up to 17g	
Shock		50 g 3 halfsine 11 msec 6 directions	
Vibration (sinusoidal)		10 g-PK from 70 to 20000 Hz (MIL STD202 method 204 D condition A with 90 % of RC)	
Vibration (random at RC)		9.26 Grms (MIL STD202 method 214 A condition C with 90 % of RC)	

CURVES

Standard trip time (EN compliant)

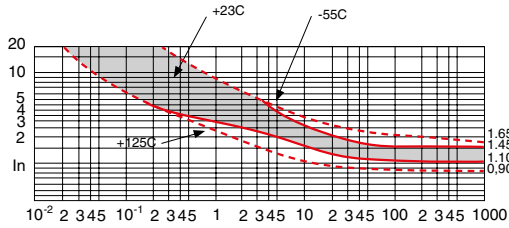

Long trip time

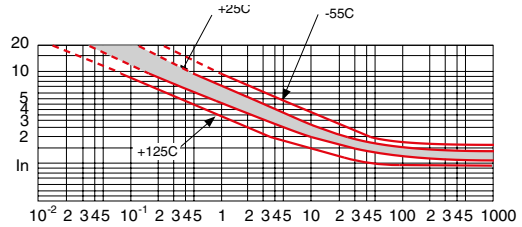

DIMENSIONS

84 306 0 & 84 306 8

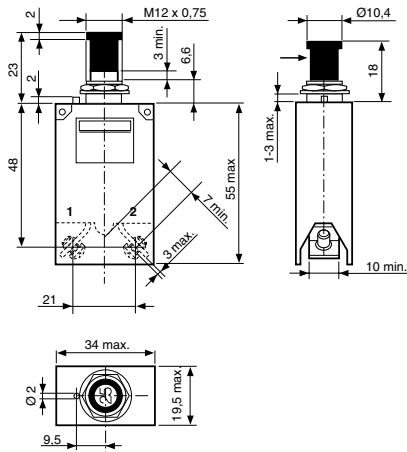

84 306 3

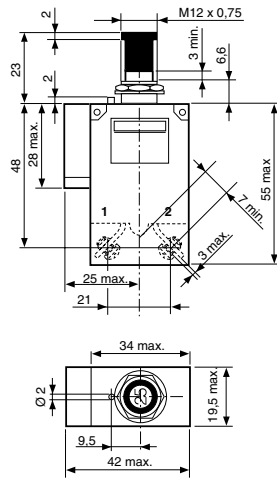

84 306 6

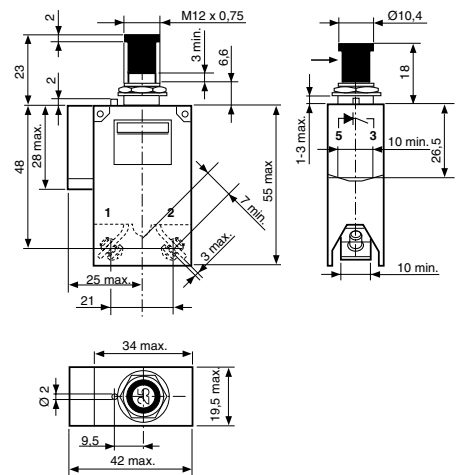

84 306 6 Bus-Bar EN 3661-006

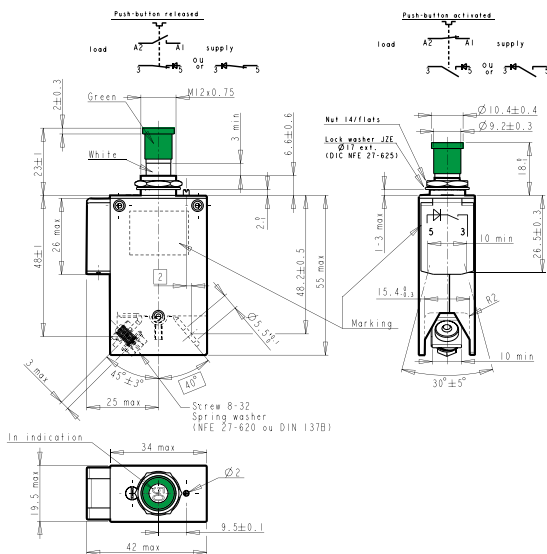

PANEL CUTOUT RECOMMENDATION

Thickness 1.6 mm → 3 mm

Versions 84 306 0 - 3 - 6

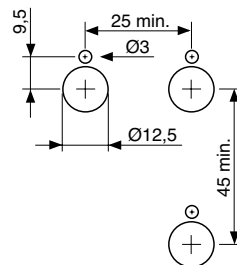

84 306 6 Bus-Bar EN 3661-006

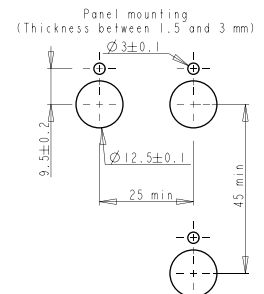

# BIG MODEL CIRCUIT BREAKER THREE POLE

## DGMT



### REFERENCES

Rating	No signal contact			No signal contact long trip time	Non polarised/polarised signal contact		Polarised signal contact
15 A	84 313 015						
20 A	84 313 020	84 313 036	84 313 061	84 313 820	84 313 320/620	84 313 316/613	84 313 621/631
25 A	84 313 025	84 313 037	84 313 062	84 313 825	84 313 325/625	84 313 317/617	84 313 622/632
30 A				84 313 830	84 313 330/630		
35 A	84 313 035	84 313 038	84 313 063	84 313 835	84 313 335/635	84 313 318/618	84 313 623/633
41 A	84 313 041			84 313 840			
50 A	84 313 050	84 313 058	84 313 066	84 313 850	84 313 350/650	84 313 319/619	84 313 624/634
60 A				84 313 860			

### Mounting hardware

Threaded barrel	M12-0.75	<input checked="" type="checkbox"/>	<input checked="" type="checkbox"/>	<input checked="" type="checkbox"/>	<input checked="" type="checkbox"/>	<input checked="" type="checkbox"/>	<input checked="" type="checkbox"/>	<input checked="" type="checkbox"/>
	M12-100							
	7/16							
Terminal Screw	8-32 UNC		<input checked="" type="checkbox"/>	<input checked="" type="checkbox"/>	<input checked="" type="checkbox"/>	<input checked="" type="checkbox"/>	<input checked="" type="checkbox"/>	<input checked="" type="checkbox"/>
	M4	<input checked="" type="checkbox"/>						
Hole ø5.5 for Bus-Bar & 40° angle				<input checked="" type="checkbox"/>				<input checked="" type="checkbox"/>

### Button

Green color				<input checked="" type="checkbox"/>	<input checked="" type="checkbox"/>	<input checked="" type="checkbox"/>	<input checked="" type="checkbox"/>
Black color	<input checked="" type="checkbox"/>	<input checked="" type="checkbox"/>	<input checked="" type="checkbox"/>				

### Conformity standard

EN 2665	003	004					
EN 3662					004/005	004/005	006
10-60806 like				<input checked="" type="checkbox"/>			

### Mass / MTBF / Vibration / Technical file

Mass without mounting hardware (g)		156		156		161	
Mass with mounting hardware (g)		165		165		170	
MTBF FH (Typical)		> 5 M		> 5 M		> 26 M	
MIL vibration condition Sinus/Random		A & C		A & C		A & C	
Technical File	-	SP4679	ASNE459	-	-	SP4340	SP4346

### GENERAL CHARACTERISTICS

#### Electrical

	115/200 VAC (400 Hz)	115/200 VAC 60 Hz-230/400 VAC 50 Hz
Breaking current 1CO + 2OCO	2000 A ; 1500 A long trip	CONTACT CROUZET
Dielectric	1500 V	
Endurance (electric overloads)	5000 (with cos fi: 0.7)	
Insulation resistance	above 100 MΩ	
Working life (endurance) at 5xRC	50 cycles	
Auxiliary contact current	0.1..0.2 A	
Voltage drop compliance	EN2665/3662	

#### Mechanical

Operating force	20N<push<80N / 5N<pull<45N
Endurance (manual open/close)	no load : 5000 cycles on resistive load : 2500 cycles
Tightening torque	barrel nut: recommended: 4 ± 0.25 N.m maximum: 5.5 N.m terminal screw: recommended: 2.35 ± 0.15 N.m maximum : 2.5 N.m

#### Environmental

Salt spray	48h / 5% NaCl
Humidity: Test b	RTCA DO160 / 10 cycles
Operating temperature	-55°C +90°C
Acceleration	up to 40 g
Shock	50 g 3 halfsine 11 msec 6 directions
Vibration (sinusoidal)	10 g-PK from 70 to 20000 Hz (MIL STD202 method 204 D condition A with 90 % of RC)
Vibration (random at RC)	9.26 Grms (MIL STD202 method 214 A condition C with 90 % of RC)

**CURVES**

**Standard trip time (EN compliant)**

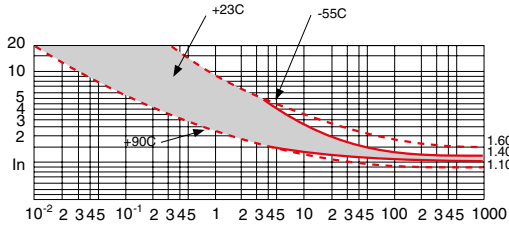

**Long trip time**

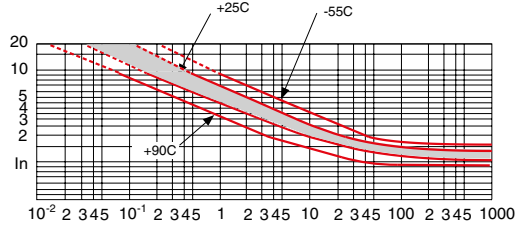

**DIMENSIONS**

84 313 0

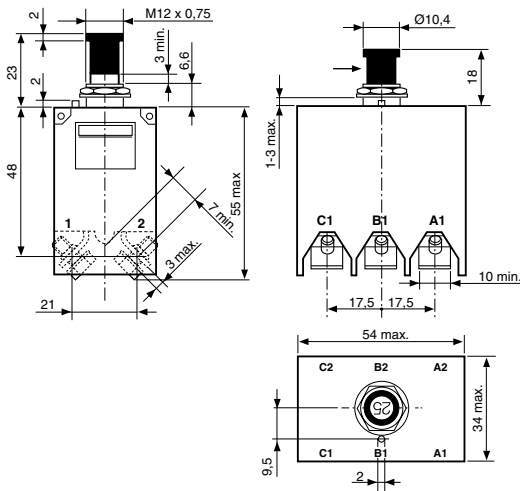

84 313 3 - 84 313 6

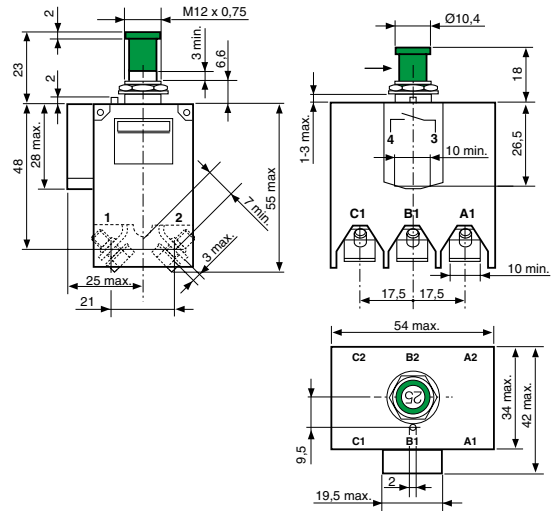

84 313 6 Bus-Bar EN 3662-006

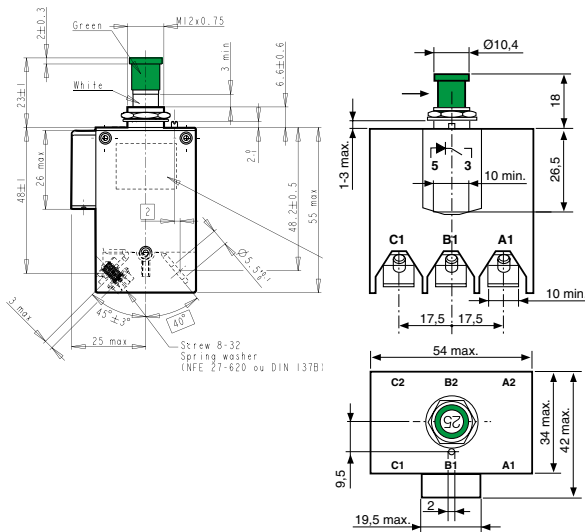

**PANEL CUTOUT RECOMMENDATION**

› Thickness 1.6 mm → 3 mm

Versions 84 313 0 - 3 - 6

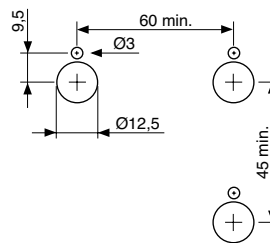

Versions Bus-Bar EN 3662-006

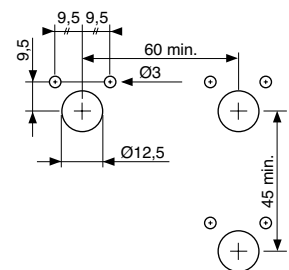



# FROG LEGS TERMINALS

## SMALL MODEL CIRCUIT BREAKER



### REFERENCES

Rating	1 pole 45°	1 pole 45°	1 pole 60°	3 pole 45°	3 pole 60°
0.5 A	84 406 011				
1 A	84 406 001	84 437 001	84 437 201	84 417 001	84 417 201
2 A	84 406 002	84 437 002	84 437 202	84 417 002	84 417 202
2.5 A	84 406 012	84 437 012	84 437 212	84 417 012	84 417 212
3 A	84 406 003	84 437 003	84 437 203	84 417 003	84 417 203
4 A*					
5 A	84 406 005	84 437 005	84 437 205	84 417 005	84 417 205
6 A*					
7.5 A	84 406 007	84 437 007	84 437 207	84 417 007	84 417 207
10 A	84 406 010	84 437 010	84 437 210	84 417 010	84 417 210
15 A	84 406 015	84 437 015	84 437 215	84 417 015	84 417 215
20 A	84 406 020	84 437 020	84 437 220	84 417 020	84 417 220
25 A	84 406 025	84 437 025	84 437 225	84 417 025	84 417 225
30 A		84 437 030	84 437 230	84 417 030	84 417 230

\* contact Crouzet for this rating

### Mounting hardware

	M12-0.75				
Threaded barrel	M12-100				
	7/16	●	●	●	●
Terminal Screw	6-32 UNC	●			
	M4		●	●	●

### Button color

Green					
Black	●	●	●	●	●

### Conformity standard

EN 2495*	●	●	●		
EN 2995*	●	●	●		
EN 2592*				●	●
EN 2996*				●	●
EN 3774*				●	●
MS26574 **	QPL				

\* for performance \*\* for terminal configuration

### Mass/MTBF/technical file

Mass without mounting hardware (g)	< 18	< 18	< 19	< 54	< 56
Mass with mounting hardware (g)	< 20	< 20	< 21	< 63	< 65
MTBF FH (Typical)	> 7.2 M	> 7.2 M	> 7.2 M	> 1.7 M	> 1.7 M
Technical file	SP 990100	SP 991700	SP 992000	SP 991900	SP 992100

### GENERAL CHARACTERISTICS

Electrical	Single Pole	Three pole
Breaking current 1CO + 2OCO	28 VDC 6000 A	115 VAC (400 Hz) 2500 A
Dielectric	1500 V	1500 V
Endurance cycles	5000 (with L/R: 5 ms)	5000 (with cos fi: 0.7)
Insulation resistance	above 100 MΩ	above 100 MΩ
Working life (endurance) at 5xRC	50 cycles	50 cycles
Auxiliary contact current (if present)	0.1..0.2 A	0.1..0.2 A
Voltage drop compliance	EN2495/2995/MS3320/AS33201	EN2495/2995/MS3320/AS33201
		MS14154/AS14154A/EN2592/2996/3774
Mechanical		
Operating force	3,5N<push<45N / 5N<pull<30N	8N<push<80N / 5N<pull<80N
Endurance	mechanical (no load) 5 000 cycles on resistive load 2 500 cycles	mechanical (no load) 5000 cycles on resistive load 2500 cycles
Tightening torque (barrel nut)	recommended: 4 ± 0.25 N.m maximum : 5.0 N.m	recommended: 4±0.25 N.m maximum: 5.0 N.m
Tightening torque (terminal screw)	recommended: 1.6 ± 0.1 N.m maximum : 2.0 N.m	recommended: 1.6±0.1 N.m maximum: 2.0 N.m
Environmental		
Salt spray	48h 5% NaCl	
Humidity: Test b	RTCA DO160 10 cycles	
Operating temperature	-60°C +125°C for all ratings except 30 A: - 60°C + 90°C	
Acceleration (centrifugal)	up to 40 g	
Shock	50 g alfsine 11 msec	

**CURVES**

Trip times envelope for temperature from -55°C to 125°C (direct overload)

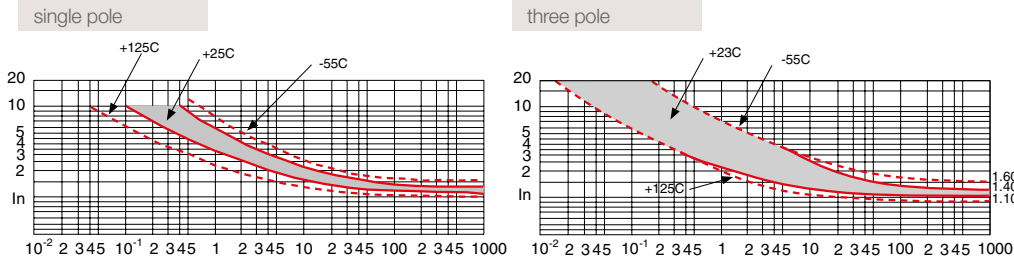

Maximum and minimum limit of ultimate trip

Rating	1.5 → 5 A	7.5 → 25 A
Non tripping point at 25°C	1.15 * RC	1.15 * RC
Tripping point at 25°C	1.4 * RC	1.4 * RC
Tripping time at 2 * RC	2 s → 15 s	4 s → 20 s
Non tripping point at 125°C	1 * RC	1 * RC

**DIMENSIONS**

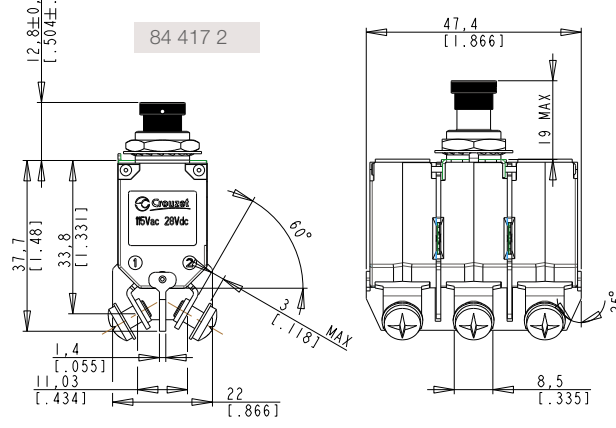
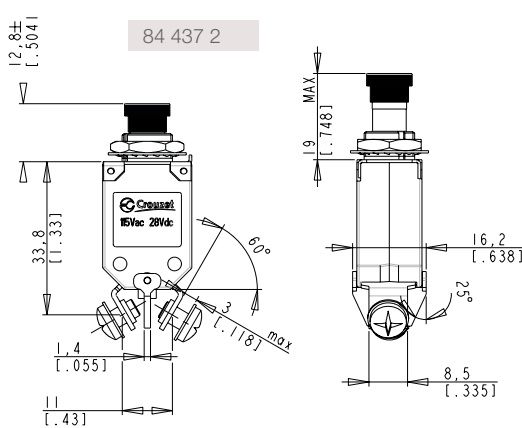
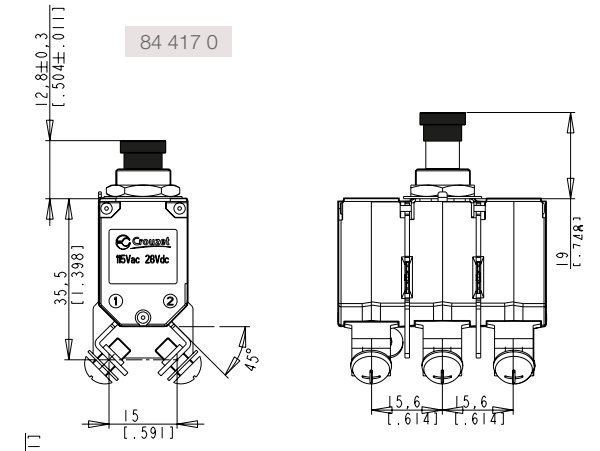
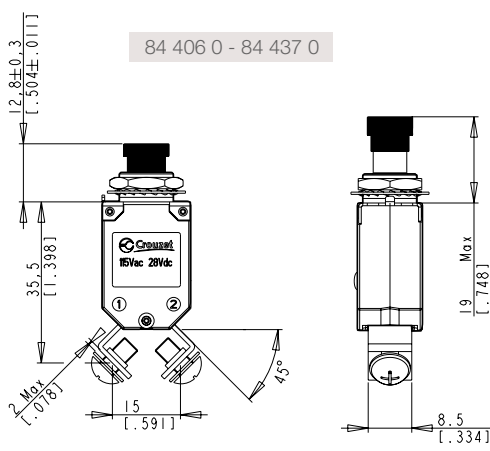

**PANEL CUTOUT RECOMMENDATION**

› Thickness 1.6 mm → 3 mm

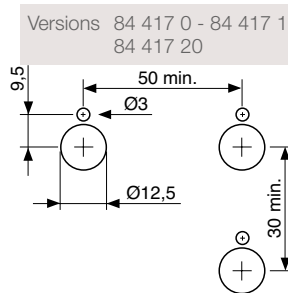
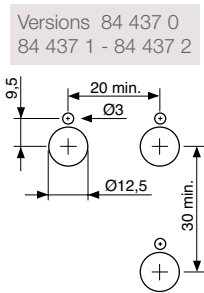
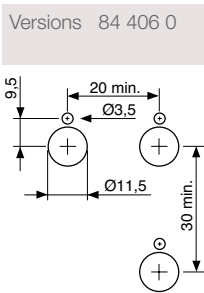

# PUSH-PULL PUSH-FIT 6.3 MM BLADE

## SMALL MODEL CIRCUIT BREAKER



### REFERENCES

Rating	no auxiliary contacts	no auxiliary contacts	no polarised/polarised	no auxiliary contacts
0.5 A		84 408 111		84 418 011
1 A	84 408 001	84 408 101	84 408 801/601	84 418 001
2 A	84 408 002	84 408 102	84 408 802/602	84 418 002
2.5 A	84 408 012	84 408 112	84 408 812/612	84 418 012
3 A	84 408 003	84 408 103	84 408 803/603	84 418 003
4 A	84 408 004	84 408 104	84 408 804/604	84 418 004
5 A	84 408 005	84 408 105	84 408 805/605	84 418 005
6 A	84 408 006	84 408 106	84 408 806/606	84 418 006
7.5 A	84 408 007	84 408 107	84 408 807/607	84 418 007
10 A	84 408 010	84 408 110	84 408 810/610	84 418 010
15 A	84 408 015	84 408 115	84 408 815/615	84 418 015
20 A	84 408 020	84 408 120	84 408 820/620	84 418 020
25 A	84 408 025	84 408 125	84 408 825/625	84 418 025
<b>Mounting hardware</b>				
Straight terminals without screws	●	●	●	●
Barrel threadings				
Conical barrel	●	●	●	●
<b>Button</b>				
Green color			●	
Black color	●	●		●
Long neck (long button)		●	●	
<b>Conformity standard</b>				
EN 2495*	●			●
EN 2995*		004	005	
EN3773-006	●	●		
EN3774-006				●
AS 33201	●	●	●	
* for thermal performance and auxiliary contact performance				
<b>Mass/MTBF / Technical file</b>				
No mounting hardware	< 14,5	< 15,5	< 16,5	< 51
MTBF FH (Typical)	> 7.2 M	> 7.2 M	> 3.6 M	> 1.7 M
Technical file	SP 991600	SP 991800	SP 991800	SP 991500

### GENERAL CHARACTERISTICS

Electrical	Single pole		Three pole
Breaking current 1CO + 2OCO	28 VDC	115 VAC (400 Hz)	115/200 VAC (400 Hz)
Dielectric	6000 A	2500 A	2000 A
Endurance cycles	1500 V	1500 V	1500 V
Insulation resistance	5000 (with L/R: 5 ms)	5000 (with cos fi: 0.7)	5000 (with cos fi: 0.7)
Working life (endurance) at 5xRC	above 100 MΩ	above 100 MΩ	above 100 MΩ
Auxiliary contact current (if present)	50 cycles	50 cycles	50 cycles
Voltage drop compliance	0.1..0.2 A	0.1..0.2 A	0.1..0.2 A
	EN2495/2995/MS3320/AS33201	EN2495/2995/MS3320/AS33201	MS14154/AS14154A/EN2592/2996/3774
<b>Mechanical</b>			
Operating force	3,5N< push<45N / 5N<pull<30N		8N<push<80N / 5N<pull<80N
Endurance	mechanical (no load) 5 000 cycles		mechanical (no load) 5000 cycles
Tightening torque (barrel nut)	on resistive load 2 500 cycles		on resistive load 2500 cycles
Tightening torque (terminal screw)	recommended: 4 ± 0.25 N.m maximum : 5.0 N.m		recommended: 4 ± 0.25 N.m maximum : 5.0 N.m
	recommended: 1.6 ± 0.1 N.m maximum : 2.0 N.m		recommended: 1.6 ± 0.1 N.m maximum : 2.0 N.m
<b>Environmental</b>			
Salt spray	48h 5% NaCl		
Humidity: Test b	RTCA DO160 10 cycles		
Operating temperature	-60°C +125°C for all ratings except 30 A: - 60°C + 90°C		
Acceleration (centrifugal)	up to 40 g		
Shock	50 g 3 halfsine 11 msec		
Vibration (sinusoidal) single pole	10 g-PK from 70 to 2000 Hz (MIL STD 202 method 204 D condition B with 90% of RC)		
Vibration (random) single pole	9.26 Grms (MIL STD 202 method 214 A condition E with 90% of RC)		

# PUSH-FIT 0.25 INCH TAB

## CURVES

**Trip times envelope for temperature from -55°C to 125°C (direct overload)**

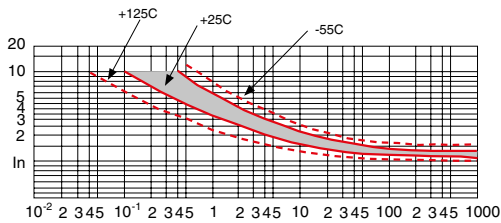

**Maximum and minimum limit of ultimate trip**

Rating	1.5 → 5 A	7.5 → 25 A
Non tripping point at 25°C	1.15 * RC	1.15 * RC
Tripping point at 25°C	1.4 * RC	1.4 * RC
Tripping time at 2 * RC	2 s → 15 s	4 s → 20 s
Non tripping point at 125°C	1 * RC	1 * RC

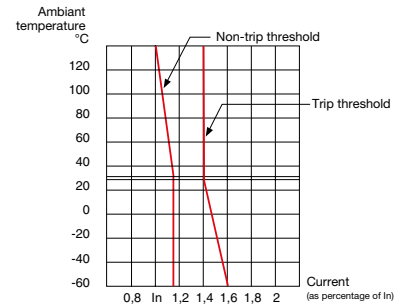

## DIMENSIONS

84 408 1

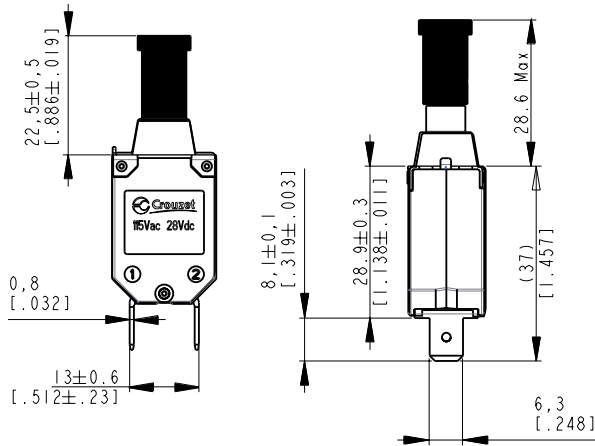

84 408 0

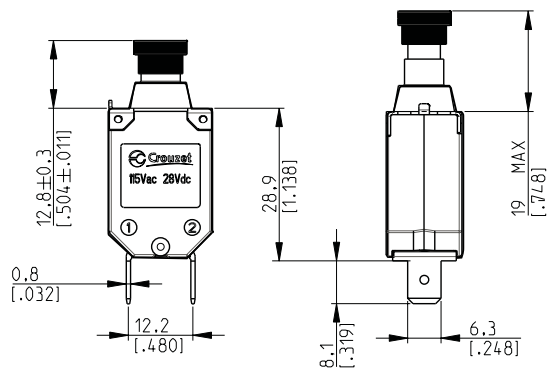

84 418 0

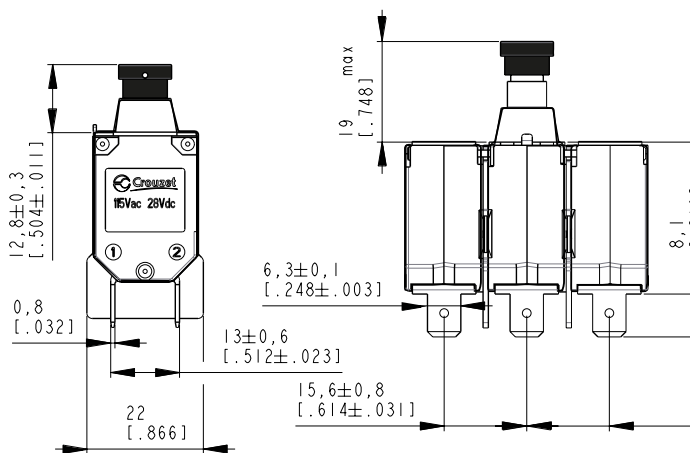

## PANEL CUTOUT RECOMMENDATION

➤ Required panel thickness for centring grommet 79219333: 1.6 mm

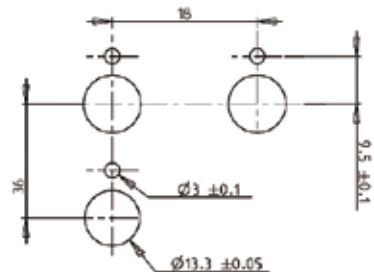

# PUSH-PUSH & FLYING LEADS VERSION

## SINGLE POLE SMALL MODEL CIRCUIT BREAKER



Read also p. 48

### REFERENCES

Rating	Faston	Flying leads
1 A	84 405 001	
1.5 A		84 405 040
2 A	84 405 002	
2.5 A	84 405 012	
3 A	84 405 003	
5 A	84 405 005	84 405 045
7.5 A	84 405 007	
10 A	84 405 010	
15 A	84 405 015	
20 A	84 405 020	
25 A	84 405 025	

### Mounting hardware

	Faston terminal	Barrel nut M12-100 + 500mm flying leads
--	-----------------	---

### Button color

White	●	●
-------	---	---

### Conformity standard

Air 6 625-403	●	●
GAM TI-II-40	●	●
EN 3773-3774*	●	●

\* our equipment complies with EN standards

### Mass / MTBF / Technical file

Weight	< 15	< 25
MTBF FH (Typical)	> 3.6 M	> 3.6 M
Technical file		SP 4397 & SP 9925

### GENERAL CHARACTERISTICS

#### Electrical

	28 VDC	115 VAC (400 Hz)	115 VAC 60 Hz-230 VAC 50 Hz
Breaking current 1CO + 2OCO	3000 A	1500 A	CONTACT Crouzet
Dielectric	1500 V	1500 V	
Endurance cycles	5000	5000	
Insulation resistance	above 100 MΩ	above 100 MΩ	
Working life (endurance) at 5° RC	1000 cycles	1000 cycles	
Auxiliary contact current	0.1..0.2 A	0.1..0.2 A	
Voltage drop compliance	EN2495/2995/MS3320/AS33201	EN2495/2995/MS3320/AS33201	

#### Mechanical

Operating force		
Endurance	no load	40 000 cycles
	on resistive load	40 000 cycles
Tightening torque (barrel nut)	recommended: 4 N.m ; Max.: 5 N.m	
Tightening torque (terminal screw)	1.7 N.m ±0.1	

#### Environmental

Salt spray	48h	5% NaCl
Humidity: Test b	RTCA D0160	10 cycles
Operating temperature	-60°C +125°C	
Acceleration	up to 20 g	
Shock	up to 50 g (11 ms)	
Vibration (sinusoidal)		10 g-PK from 10 to 2000 Hz
Vibration (random at RC)		up to 9.26 Grms from 10 to 2000 Hz

**CURVES**

**Trip times envelope for temperature from -55°C to 125°C (direct overload)**

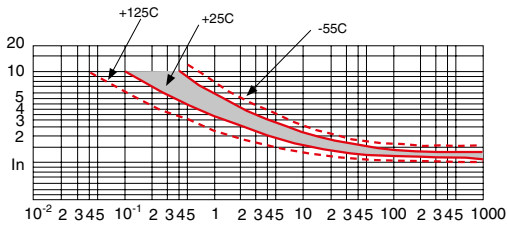

**Maximum and minimum limit of ultimate trip**

Rating	1 → 3 A	5 → 25 A	5 → 25 A
Non tripping point at 25°C	1.15 In	1.15 In	1.15 In
Tripping point at 25°C	1.4 In	1.4 In	1.4 In
Tripping time at 2 ° RC	2 s → 15 s	4 s → 16 s	6 s → 20 s
Non tripping point at 125°C	In	In	In

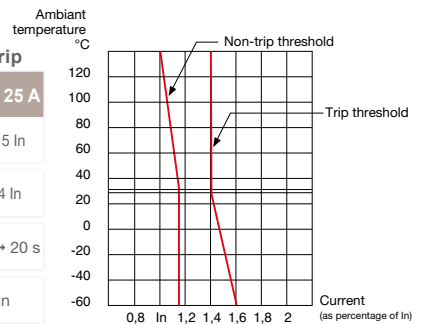

**DIMENSIONS**

84 405 0

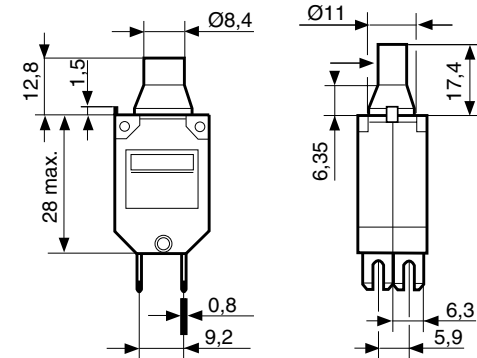

84 405 040

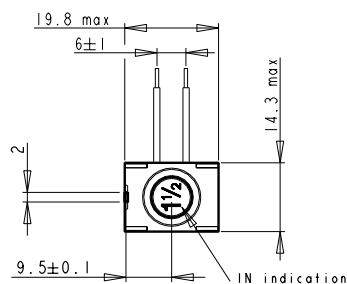
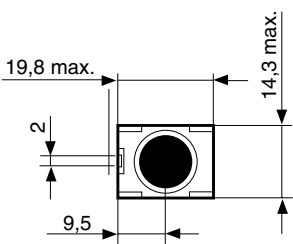
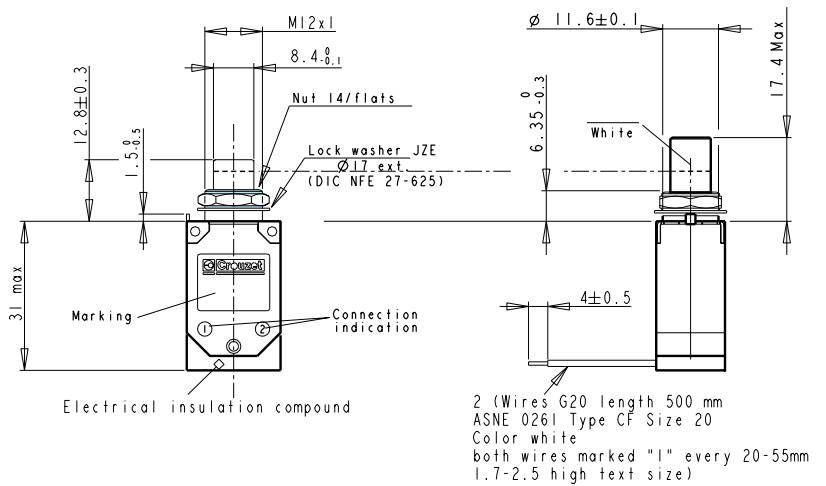

**PANEL CUTOUT RECOMMENDATION**

› Thickness 1.6 mm → 3 mm

Version 84 405 0

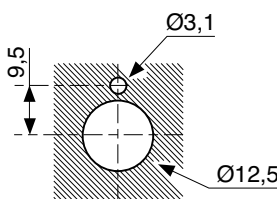

Version 84 405 04X

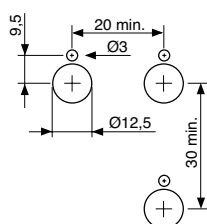

# GROUND FAULT & ARC FAULT CIRCUIT BREAKER

## GF-AFCB 115/200 VAC 360 .. 800 HZ



Read also p. 8-11

### REFERENCES

Rating	GF-AFCB**	Three pole AFCB	Single pole AFCB	Software + Breaker reader
1 A				
3 A	84 411 136	84 411 103	84 401 503	
5 A	84 411 137	84 411 105	84 401 505	
7.5 A	84 411 138	84 411 107	84 401 507	
10 A	84 411 139	84 411 110	84 401 510	
15 A	84 411 140	84 411 115	84 401 515	
20 A	84 411 141	84 411 120	84 401 520	
25 A	84 411 142	84 411 125	84 401 525	

Accessories: breaker reader + CD

84 411 101

\*\* on request the GF-CB is available in star or triangle configuration with different thresholds

### Mounting hardware

Threaded barrel	M12-0.75				
	M12-100	●	●	●	
Terminal Screw	7/16				
	8-32 UNC	●	●	●	
	M4				

### Button color

Green			●	
Black	●	●		

### Conformity standard

EN 2592 - EN 2996*	●	●		
EN 2495*			●	
AS 5692	●	●	●	

\* for thermal part

### Mass / MTBF / Technical file

Without mounting hardware	< 141	< 141	< 31	
With mounting hardware	< 150	< 150	< 33	
MTBF FH (Typical)	> 150 000	> 150 000	> 450 000	

## GENERAL CHARACTERISTICS

### Electrical

Breaking current 1CO + 2OCO	115/200 VAC (400 Hz)	2000 A	
Dielectric		1500 V	
Endurance cycles		5000 (with cos φ: 0.7)	
Insulation resistance		above 100 MΩ	
Working life (endurance) at 5° RC		50 cycles	
Auxiliary contact current		0.1..0.2 A	
Voltage drop compliance		MS14154/AS14154A/EN2592/2996/3774	

### Mechanical

Operating force	8N<push<80N	5N<pull<30N
Endurance	no load	5 000 cycles
	on resistive load	5 000 cycles
Tightening torque (barrel nut)	recommended: 4 N.m ; Max.: 5 N.m	
Tightening torque (terminal screw)	1.7 N.m +/-0.1	

### Environmental

Salt spray	According DO160 section 14 category B
Humidity	According DO160 section 6 category B
Operating temperature (1 to 15 A)	-60°C +125°C
Operating temperature (20 and 25 A)	-60°C +90°C
Operating temperature (Arc fault and ground fault detection)	-40°C +71°C
Acceleration (centrifugal)	17g
Shock	up to 50 g (11 ms) -1/2 sine
Vibration (sinusoidal)	10 g-PK from 5 to 2000 Hz
Vibration (random at RC)	5.82 Grms from 10 to 2000 Hz





# DUMMY CIRCUIT BREAKER

## DUMMY & WATERTIGHT PUSH PULL CB



84 404 001



84 404 011



84 404 004



84 411 860



84 313 626



84 404 007

### CHOICE BY CIRCUIT BREAKER SIZE

#### Small Model Single Pole DPMU

Initial Family	Signal contact	Ref.	Conformity	Barrel threadings			Terminal screw		Control button	Technical file
				M12-0.75	M12-100	7/16	H8-32	M4		
Reset button	Yes	84 404 001	ABS0064		●		●		Active	
84 401 0xx	Yes	84 404 002	E0486A01		●				Pushed in	SP4361
84 405 0xx (push-push)	No	84 404 003			●				Without	SP4362
84 400 0xx (MS3320)	No	84 404 004				●	●		Pushed in	SP4365
84 402 0xx	No	84 404 005			●			●	Pushed in	SP4369
84 401 8xx	Yes	84 404 006	E0486B01		●		●		Without	
Frog legs	No	84 404 009				●	6-32UNC2A		Without	SP9903
Frog legs	Yes	84 404 010				●	6-32UNC2A		Without	SP9904
84 402 0xx	No	84 404 011			●			●	Pushed in	SP9910
Frog legs	Yes	84 404 013			●			●	Without	SP9914
84 401 6xx	Yes	84 404 015	E0486B05		●		●		Without	

#### Small Model Three Pole DPMT

Initial Family	Signal contact	Ref.	Conformity	Barrel threadings			Terminal screw		Control button	Technical file
				M12-0.75	M12-100	7/16	H8-32	M4		
84 411 8xx	Yes	84 404 007	E0486B03		●		●		Without	
84 411 860	Yes	84 411 860	E0486A03		●		●		Pushed in	

#### Big Model Single Pole DGMU

Initial Family	Signal contact	Ref.	Conformity	Barrel threadings			Terminal screw		Control button	Technical file
				M12-0.75	M12-100	7/16	H8-32	M4		
84 306 65x	Yes	84 404 016	E0486B06	●			●			

#### Big Model Three Pole DGMT

Initial Family	Signal contact	Ref.	Conformity	Barrel threadings			Terminal screw		Control button	Technical file
				M12-0.75	M12-100	7/16	H8-32	M4		
84 313 6xx	Yes	84 313 626	E0486A04	●			●		Pushed in	SP4347
84 313 0xx	No	84 313 044		●				●	Pushed in	SP4335
84 313 6xx	YES	84 404 014	E0486B04	●			●		Without	

### CHOICE BY STANDARD

ASNE0486	EN4728	Corresponding functional Circuit Breaker	Model code	Dimension & Alt Hardware	Part-number
E0486B01	EN4728B01C	EN2995-004	B (no control button)	01 C	84 404 006
E0486B03	EN4728B03C	EN2996-004	B (no control button)	03 C	84 404 007
E0486B04	EN4728B04C	EN3672-006	B (no control button)	04 C	84 404 014
E0486B05	EN4728B05C	EN2995-005	B (no control button)	05* C	84 404 015
E0486B06	EN4728B06C	EN3661-006	B (no control button)	06 C	84 404 016

\* No power terminals

› To understand attachment hardware codification, please see page 19.

**DIMENSIONS**

84 404 001

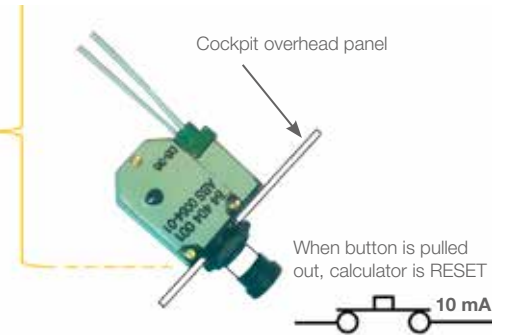
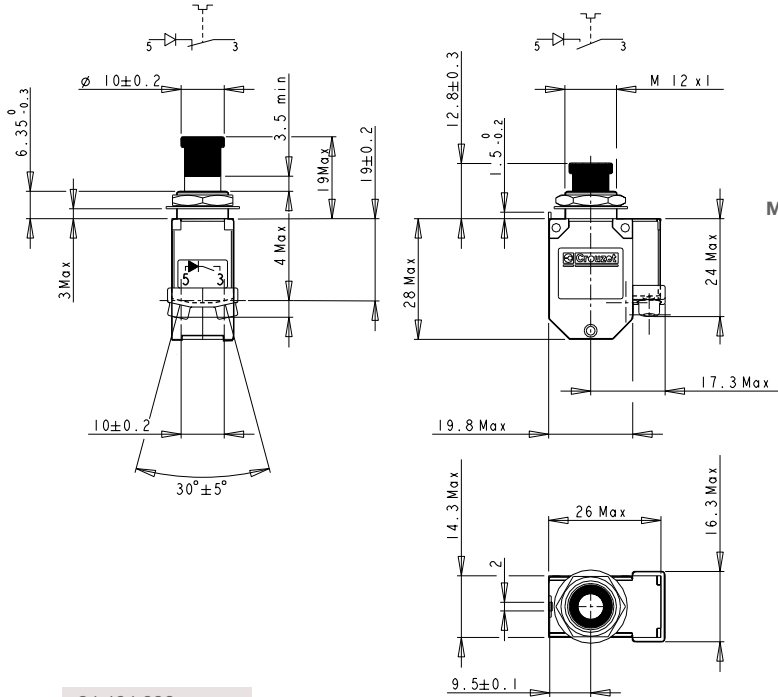

Due to the upside down position of the CB and watertightness, there is no water ingress even with condensation

84 404 006

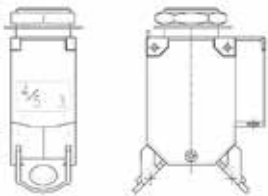

84 404 011

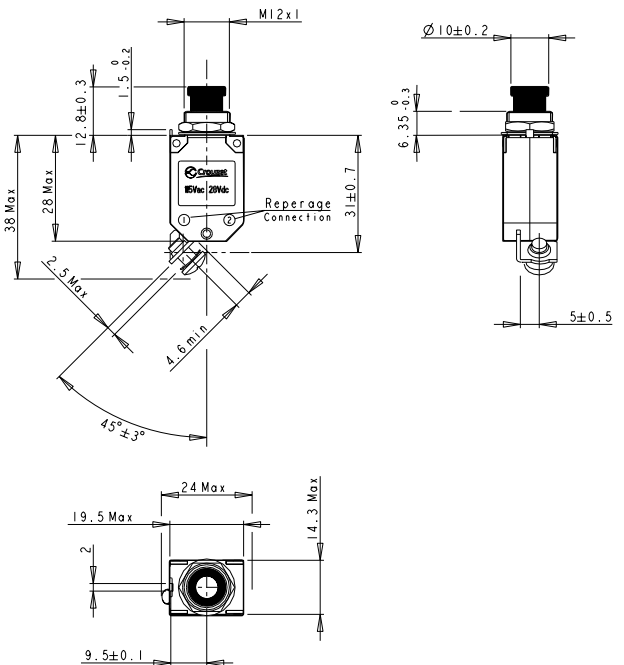

**PANEL CUTOUT RECOMMENDATION**

› Thickness 1.6 mm → 3 mm

Please, refer to the according technical file

# ACCESSORIES

## ACCESSORIES

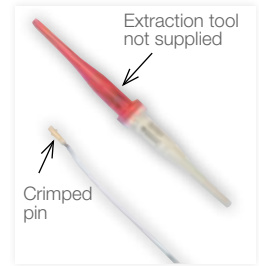

### REFERENCES

Rating	Gag	Caps	Covers	Auxiliary contact pin
red gag	23 422 009			
grey cap	panel hole diam 12.5mm	24 323 003		
brown cap	panel hole diam 12.5mm	24 323 005		
opaque covers	Barrel M12*1		79 254 157	
	Barrel M12*0.75		79 254 154	
	Barrel 15/32		79 254 155	
	Barrel 7/16		79 254 156	
clear covers (see through)	Barrel M12*1		79 254 150	
	Barrel M12*0.75		79 254 151	
	Barrel 15/32		79 254 152	
Barrel 7/16		79 254 153		
male pin	EN 3155 -016M 2018			25 637 611

Other information				
crimping tool for pin 25637611:		crimp tool: M22520/1-01 and crimp locator: M22520/1-02		
insertion extraction tool:		Ref. Deutsch: 020-0008-20		
male pin		Ref. Deutsch: 006-0912-20		

### CONFORMITY STANDARD

IP66 & 67				
VG 95345 chap. 23				

### DIMENSIONS

79 254 -150 to -157

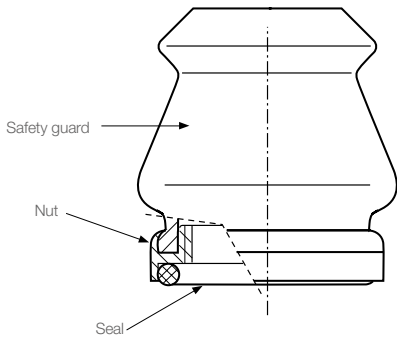

24 323 003 24 323 005

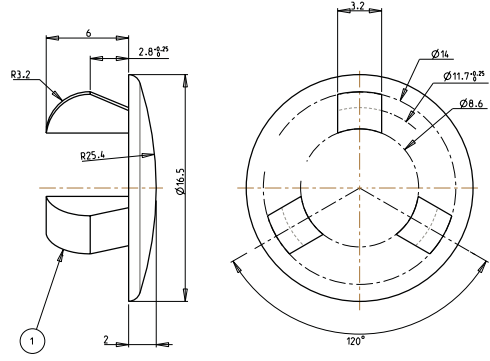

**Caution:** For good water proofness: the CB pannel must be 2.5 mm thick and positioning key hole must be «blind». Torque of 4 N.m must be applied to the nut ; not on the cover.



23 422 009

EC 79 25 40 85

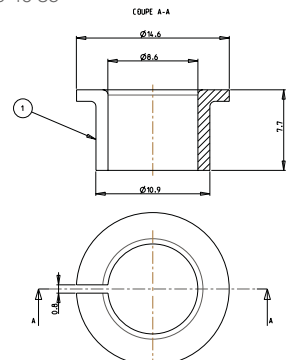

25 637 611

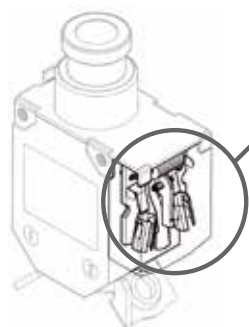

Connector pins for auxiliary contacts:  
EN 3155 - 016 M2018  
Wire gage: 18 to 24 (0.21 to 0.93mm<sup>2</sup>)

# ELECTRICAL DISTRIBUTION

## WIRE & LOAD PROTECTION

Crouzet is proud to contribute towards the “greener Aircraft” through its bus connected components and through its never ending quest for more compact and lighter solutions.

Crouzet delivers 3 standard distribution components:

- › RCCB
- › A Circuit Breaker panel Kit
- › Solid State Circuit Breakers

With smart management, loads can be powered off during some flight phases and in rush current can be reduced. This technique will decrease the electrical network complexity and weight. Using information provided by the load, SSCB and RCCB’s role can encompass wire protection and load protection

### LOAD AND WIRE PROTECTION WITH SSPC

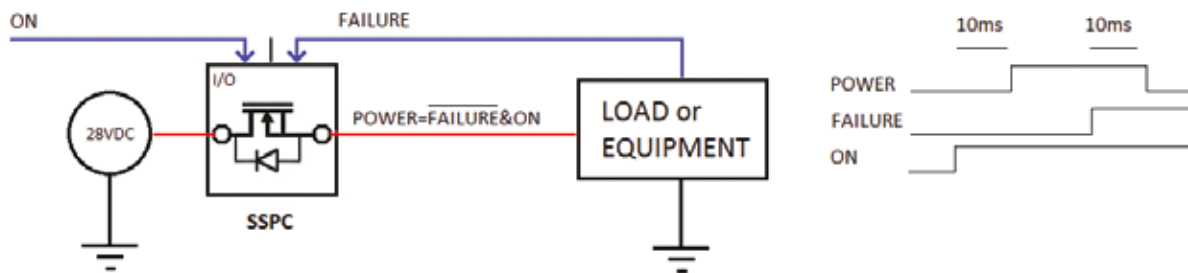

### LOAD AND WIRE PROTECTION WITH RCCB

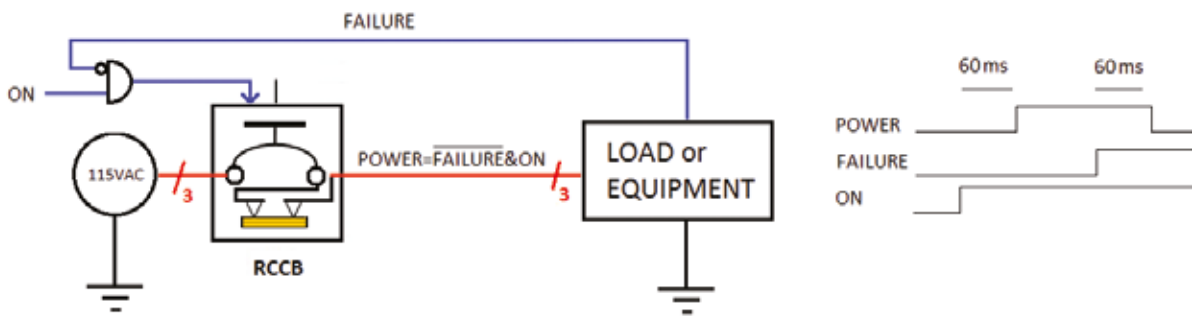

# CIRCUIT BREAKER PANEL KIT

## PANEL KIT FOR PUSH-FIT 6.3 MM BLADE CB

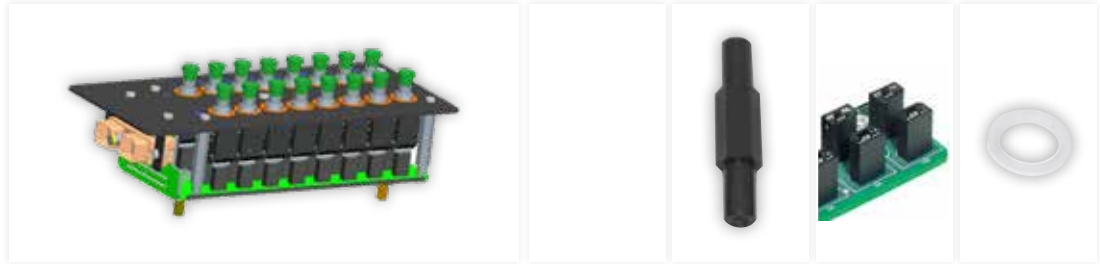

Read also page 15

### REFERENCES

	complete panel	PCB	Right angle 90°	Spacers	Straight 180°
complete panel large	84 341 641				
complete panel small	84 341 640				
spacer				79 219 431	
receptacle					25 579 113
centring grommet			Air LB		
EN 4165 connector support			79 219 440		79 219 333
PWB with 32 receptacles		79 219 439			
front plate			79 219 441/42		

### Spacer kit

5 spacers	
16 grommets	79 219 443
32 receptacles	

### Connection possibilities

- EN4165 (2 modules of 8 size 16 pins) with pins soldered on the vertical PCB
- EN4165 (2 modules of 8 size 16 pins) held by 79219440 with crimped contact pins
- Flying leads soldered on the vertical PCB

### Circuit Breaker type

Faston without auxiliary contact	84 408 0xx
Faston with auxiliary contact non polarised	84 408 8xx
Faston with auxiliary contact polarised	84 408 6xx

### Weight (g)

Without standard CB (only mechanical panel)	< 351
Panel with 16 Circuit Breakers	< 528
MTBF FH (Typical)	> 60 000

## GENERAL CHARACTERISTICS

### Electrical

Vehiculated current	15*4+6*10+6*5=150 A	from -60°C to 71°C
Vehiculated power	150*28=4200 W	
Prospective current (blocked mechanism)	1800 A	28 VDC (no copper tracks destruction)
Dielectric	500 VDC between 2 copper tracs and between each track and power feeder	

### Mechanical

	torque (max) N.m
Power stud (M6)	3.9
Every screw/spacer (M3)	2
Locktite	on every screw/spacer (not on power stud nut)

### Environmental

DO160 section	Test	category	method
4	Altitude		similarity
5	Temperature	from -60°C..71°C (with power)	test
6	Humidity		test
7	Crash	MIL STD 810E 80 ms 1/2 sine (20 g on all axes)	test
8	Vibration	MIL STD 810E helicopter random wide band+ sine strips	test
9	Explosion proofness		demonstration
10	Waterproof		N/A
11	Fluids		N/A
12	Sand and dust		similarity
13	Fungus resistance		no tested
14	Salt spray	48h no power + 48h dry	test
15	Magnetic effect		demonstration
16 → 23	EMI		N/A
25	Inflammability	FAR 25853	demonstration

## HOW DOES IT WORK?

The assembly is qualified and distributes securely up to 150 A under 71°C with a configuration carrying four 15 A, six 10 A and six 5 A Circuit Breakers (thus a total of 16 CBs).

The distribution connector can be mounted on the vertical PCB or distribution leads can be soldered on the vertical PCB.

› If leads are soldered directly on the vertical PCB, the maximum currents are:

- Red zone: 15 A max
- Yellow zone: 10 A max
- Green zone: 5 A max

Max output:  
 $4 \times 15 + 6 \times 10 + 6 \times 5 = 150 \text{ A}$

› If EN 4165 is soldered and used with leads the size 16 pins limit the current to 13 A:

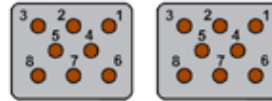

Max output:  
 $4 \times 13 + 6 \times 10 + 6 \times 5 = 142 \text{ A}$

## PIN TO CB AFFECTATIONS

EN4165

Layout 0816: 8 contacts size 16 x 2

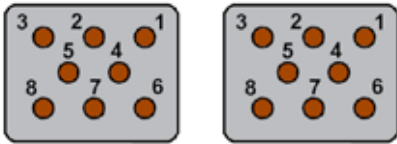

Module A	CB#
1	F6
2	F2
3	F1
4	F7
5	F3
6	F8
7	F5
8	F4

connector EN 4165 8T16

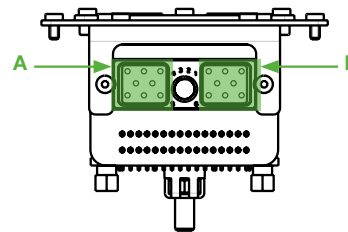

Module B	CB#
1	F9
2	F10
3	F14
4	F11
5	F15
6	F12
7	F13
8	F16

## DIMENSIONS AND SPECIFIC ZONES FOR CB RATINGS

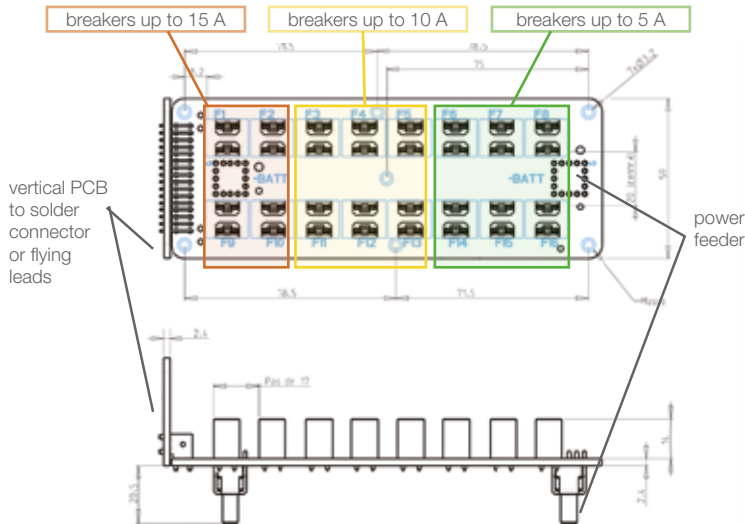

## CENTRING GROMMET

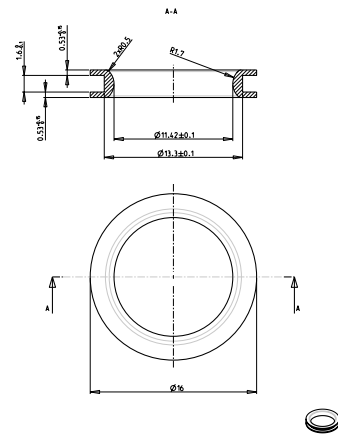

## PANEL CUTOUT RECOMMENDATION FOR CB 84 408 XXX FAMILY

› Required panel thickness for centring grommet 79219333: 1.6 mm

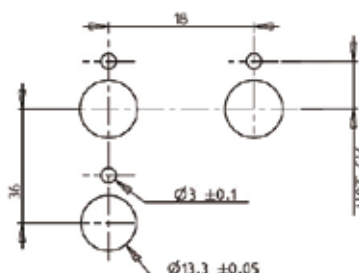

84 408 0

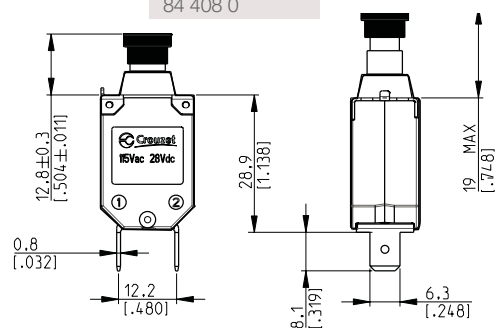



# REMOTE CONTROL CONTACTOR & CIRCUIT BREAKER

## RCCB 115/200 VAC 360-800 HZ

Read also page 16



### REFERENCES

Rating	Without current transformer	With current transformer
35 A	84 354 335	84 354 435
50 A	84 354 350	84 354 450
60 A	84 354 360	84 354 460

### GENERAL CHARACTERISTICS

#### Mounting hardware

Fixing screws (to panel or closet wall)	3 screws 10-32 UNF-3B	3 screws 10-32 UNF-3B
Connexion screws (to power feeders lugs)	6 screws 8-32 UNC-3A	6 screws 8-32 UNC-3A
Matched connector for control signals	Air LB00 1748-120.00	Sub D 15 Female
Connector retaining screw	M3x0.5	-

#### Contactur Function

Actuating voltage	17 V= ≤U <sub>s</sub> 32 V (a2 - a1 pins)	17 V= ≤U <sub>s</sub> 32 V (10 - 2 pins)
Max Pull-in current	3A during max 50 ms	3A during max 50 ms
Max. continuous hold-in current	300 mA	300 mA
Min. Hold-in voltage	10 V=	10 V=
Response time (off to on)	< 60 ms	< 60 ms
Release time (on to off)	< 60 ms	< 50 ms
Direct visual indication of contacts position on front plate	OPEN / CLOSE	OPEN / CLOSE
Auxiliary contact n°1 SPDT type Intermediate current level	Common/NC/NO: b1/c1/d1 28 VDC 3A (L/R 5 ms) - 5 VAC 250 mA	Common/NC/NO: 3/4/5 28 VDC 3A (L/R 5 ms) - 5 VAC 250 mA
Auxiliary contact n°2 SPDT type Low level current	Common/NC/NO: b2/c2/d2 3 VDC 0 to 20 mA resistive 28 VDC 200 mA (L/R 5 ms)	Common/NC/NO: 6/7/8 3 VDC 0 to 20 mA resistive 28 VDC 200 mA (L/R 5 ms)
Dielectric strength	I leakage < 1 mA @ 1500 V~	I leakage < 1 mA @ 1500 V~
Insulation resistance	≥ 100 MΩ	≥ 100 MΩ
Contactur Endurance cycles with RC at 40°C cos Fi=0.7	100 000 cycles	100 000 cycles

#### Current measurement & Breaker function

Current transformer ratio	-	0.5 Volt rms for 10 A rms
Integrated load resistance (on current transformer output)	-	50 Ω
Breaking at 115 VAC 360-800 Hz	2000 A	2000 A
Trip status auxiliary contact (incorporated diode)	28 VDC 10 to 200 mA	28 VDC 10 to 200 mA
Visual indication of trip status by R button on front plate	Yes	Yes
Operating circuit disable after break	Yes	Yes
Resetting after trip	By push on front R button	By push on front R button
Endurance at 2*RC	1 000 cycles	1 000 cycles

#### Mechanical

Operating force (R push button)	< 10 N	< 10 N
Max. admissible force (R push button)	50 N	50 N
Tightening torque (barrel nut)	3 +/- 0.2 Nm	3 +/- 0.2 Nm
Tightening torque (terminal screw)	2.3 +/- 0.1 Nm	2.3 +/- 0.1 Nm
Weight	< 550 g	< 700 g
MTBF FH (Typical)	> 300 000	> 300 000

#### Environmental

Salt spray	48h at 5% NaCl	48h at 5% NaCl
Operating temperature	-40°C to +85°C	-40°C to +85°C
Acceleration (centrifugal)	up to 10 g	up to 10 g
Shock	25 g - 11 ms	25 g - 11 ms
Vibration (sinusoidal)	10 g from 5 to 2000 Hz	10 g from 5 to 2000 Hz
Vibration (random)	5.8 g from 10 to 2000 Hz	5.8 g from 10 to 2000 Hz

84 354 3XX

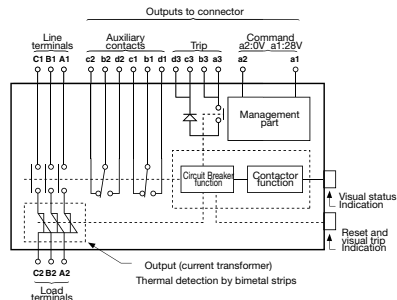

84 354 4XX

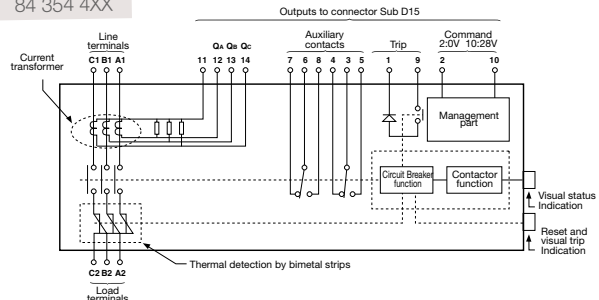

## HOW DOES IT WORK?

The RCCB merges a contactor function and a circuit breaker function in a single unit. This association gives the following unique advantages:

- › Reduction of the length of generally large cross-sections wires (mass reduction and harness simplification)
- › Reduction of voltage drop (reduced number of contacts)
- › Reduction of envelope
- › Improved reliability (less components)

The contactor is closed when 28 V is applied on the command input.

The RCCB has a status display window and a mechanical «TRIP indicator». When the CB has tripped, the mechanical «TRIP indicator» is «popped out» and must be pushed back in manually to RESET the circuit breaker (see page 16).

The «protection function» overrides the «contactor function». After tripping, the RCCB must therefore be reset manually, this avoids any risk of spurious restarting.

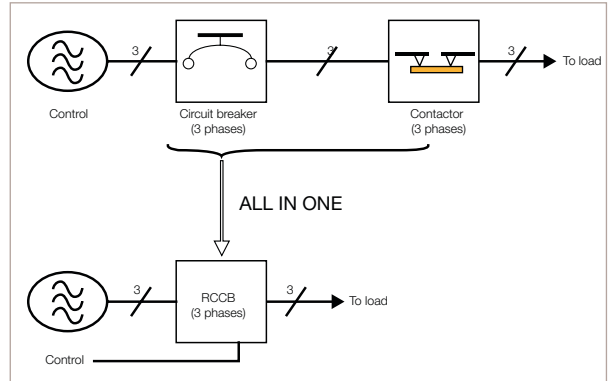

## TRIPPING CHARACTERISTICS

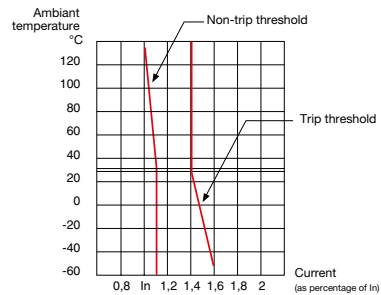
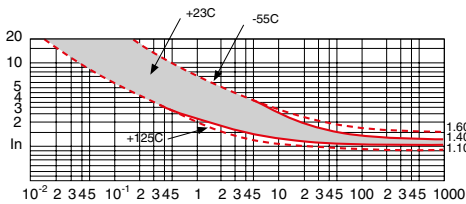

## DIMENSIONS

Without current transformer

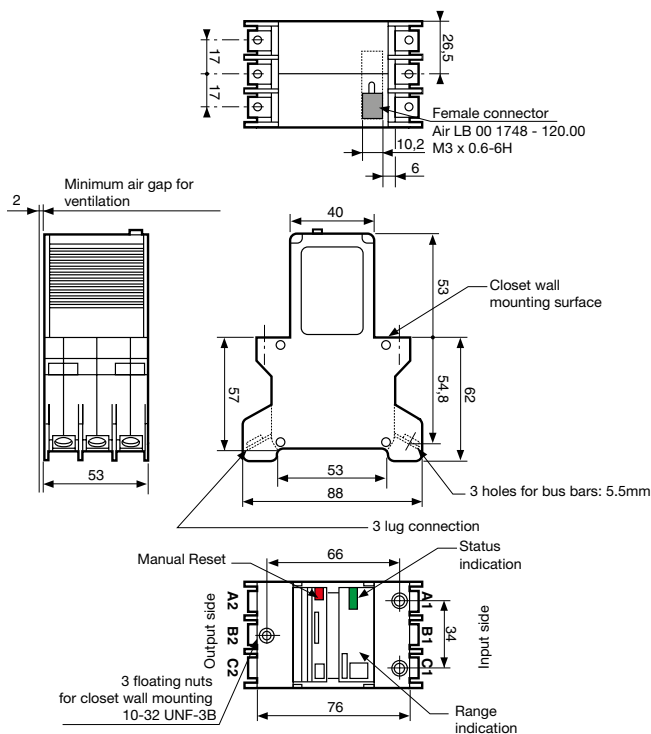

With current transformer

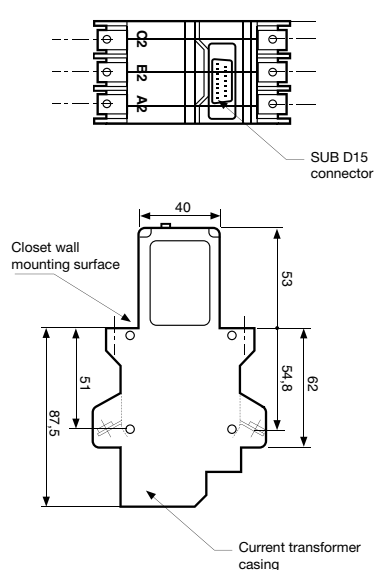

**AMERICAS****CANADA**

Tel.: +1 (855) 929-5465  
americas.custserv@crouzet.com

**MEXICO**

Tel.: +1 (855) 929-5465  
americas.custserv@crouzet.com

**USA**

+1 (855) 929-5465  
americas.custserv@crouzet.com

**COUNTRIES NOT LISTED**

+1 (855) 929-5465  
americas.custserv@crouzet.com

**EUROPE / MIDDLE EAST / AFRICA****BELGIUM**

Tel.: +32 (0) 2 620 06 05  
Fax: +32 (0) 2 461 00 23  
klantenservice@crouzet.com

**FRANCE**

Tel.: +33 (0) 475 802 101  
Fax: +33 (0) 475 828 900  
relationclient@crouzet.com

**GERMANY / AUSTRIA**

Tel.: +49 (0) 2103/9385930  
Fax: +49 (0) 2103/980-222  
kundenservice@crouzet.com

**ITALY**

Tel.: +39 (02) 38 594 099  
Fax: +39 (02) 82 952 104  
assistenzaclienti@crouzet.com

**SPAIN / PORTUGAL**

Tel.: +34 (91) 215 80 95  
Fax: +34 (93) 2 20 02 05  
atencionalcliente@crouzet.com

**SWITZERLAND**

Tel.: +41 (0) 225 67 57 90  
Fax: +41 (0) 565 88 02 75  
kundenservice@crouzet.com

**THE NETHERLANDS**

Tel.: +31 (0) 20-654 52 20  
klantenservice@crouzet.com

**UNITED KINGDOM**

Tel.: +44 (0) 2076 600 025  
customer.relation@crouzet.com

**COUNTRIES NOT LISTED**

Tel.: +33 (0) 475 802 102  
Fax: +33 (0) 475 828 900  
customer.relation@crouzet.com

**ASIA / PACIFIC****CHINA**

Tel.: +86 (75) 2 5303 200  
china@crouzet.com

**INDIA**

india@crouzet.com

**SOUTH KOREA**

Tel.: +82 (2) 2679 8312  
Fax: +82 (2) 2679 9888  
korea@crouzet.com

**EAST ASIA PACIFIC**

Tel.: +86 (21) 8025 7177  
Fax: +86 (21) 6107 1771  
eap@crouzet.com

**Warning:**

The product information contained in this catalogue is given purely as information and does not constitute a representation, warranty or any form of contractual commitment. Crouzet and its subsidiaries reserve the right to modify their products without notice. It is imperative that we should be consulted over any particular use or application of our products and it is the responsibility of the buyer to establish, particularly through all the appropriate tests, that the product is suitable for the use or application. Under no circumstances will our warranty apply, nor shall we be held responsible for any application (such as any modification, addition, deletion, use in conjunction with other electrical or electronic components, circuits or assemblies, or any other unsuitable material or substance) which has not been expressly agreed by us prior to the sale of our products.