



Miniature 10 Amps • 2PDT To MIL-R-83536 DC Suppressed Coils

SPECIFICATIONS

GENERAL

Contact Arrangement 2PDT (2 Form C)
Weight 1.6 oz approx.
 Designed to meet the requirements of MIL-R-6106

PERFORMANCE

Contact Rating (Note 1):

Resistive 10 Amps @ 28 VDC or
 115/208V 400 Hz
 (Case Grounded)
 Inductive 6 Amps @ 115/208V 400 Hz
 (Case Grounded)
 4 Amps @ 115/208V 60 Hz
 (Case Grounded)
 Motor 4 Amps @ 28 VDC or
 115/208V 400 Hz
 (Case Grounded)
 3 Amps @ 115/208V 60 Hz
 (Case Grounded)
 Lamp 2 Amps @ 28 VDC or
 115/208V 400 Hz
 (Case Grounded)
 1.5 Amps @ 115/208V 60 Hz
 (Case Grounded)

Life 100,000 operations minimum @ rated
 resistive load, 125°C

Pull In Power 500 mw approx.

Operate/Release Time:

DC Coil

15 ms max

Excluding bounce time at nominal coil voltage

Contact Bounce Time 1 ms max
 @ rated contact load, 28 VDC

Contact Voltage Drop:

Before Life 150 mv max @ 10 Amps
 and 6 VDC

After Life 175 mv max @ 10 Amps
 and 6 VDC

ENVIRONMENTAL

Temperature Range -70°C to +125°C

Vibration (Note 2) 0.12" DA 10 - 70 Hz
 30 G's 70 - 3,000 Hz

Shock (Operating)(Note 2) 200 G's 6 ms

ELECTRICAL CHARACTERISTICS

Duty Cycle Continuous

Insulation Resistance 100 megohms
 @ 500V 25°C

Dielectric Strength:

Sea Level:

Contact to Case 1,250 VRMS

Contact to Coil 1,250 VRMS

Coil to Case 1,000 VRMS

Across Open Contacts 1,250 VRMS

80,000 Feet:

All Points 350 VRMS

MIL-R-83536/10 QUALIFIED to ER level M

Notes:

1. For other ratings consult the factory.
2. For applications requiring higher shock and vibration, consult the factory.
3. AC coil line frequency 50 to 400 Hz.

COIL DATA:

MODEL BR246D PART NUMBER	BR246D-20()-6V	BR246D-80()-12V	BR246D-320()-28V	BR246D-1000()-48V
NOMINAL COIL VOLTAGE	6 VDC	12 VDC	28 VDC	48 VDC
MAXIMUM COIL VOLTAGE	8 VDC	15 VDC	29 VDC	59 VDC
PULL IN VOLTAGE (MAX @ +125°C)	4.5 VDC	9 VDC	18 VDC	36 VDC
DROP OUT VOLTAGE (MAX)	1.8 VDC	3.5 VDC	5.1 VDC	11 VDC
MAXIMUM BACK EMF	9 VDC	18 VDC	42 VDC	72 VDC
COIL RESISTANCE ± 10% @ 25°C	20 OHMS	80 OHMS	320 OHMS	1000 OHMS

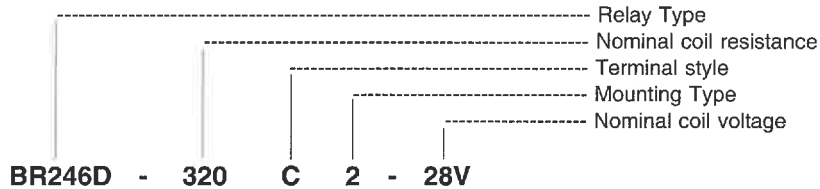

SCHEMATIC TERMINAL VIEWS

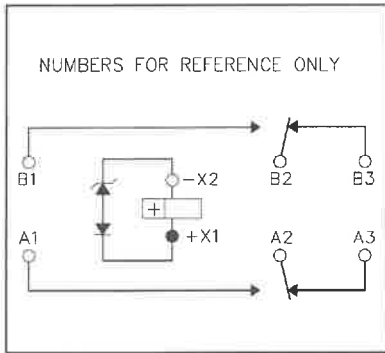

TERMINAL STYLES

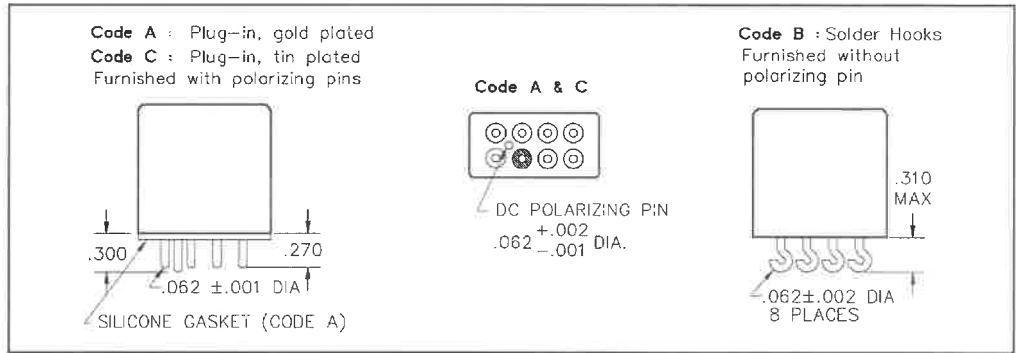

MOUNTING CODES

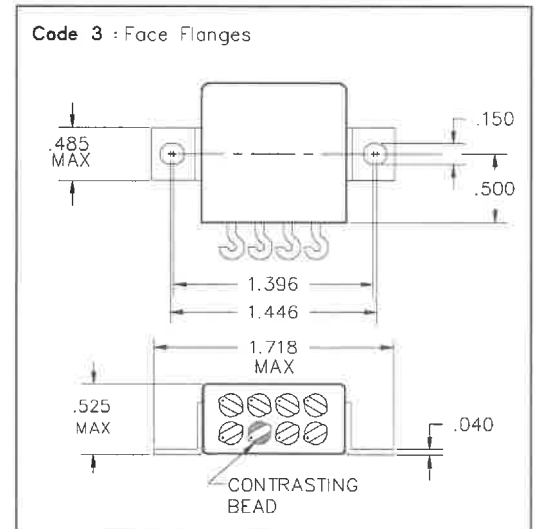
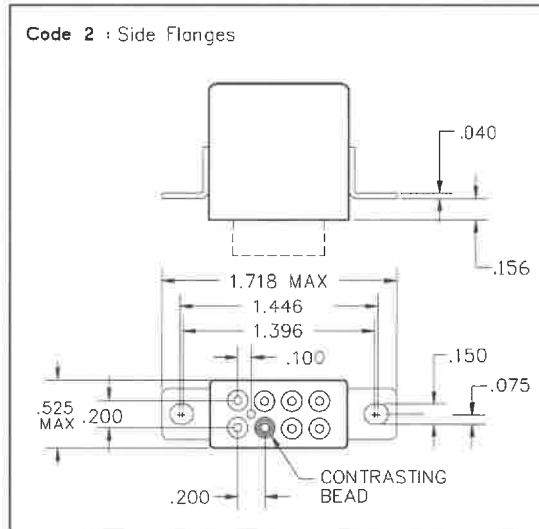
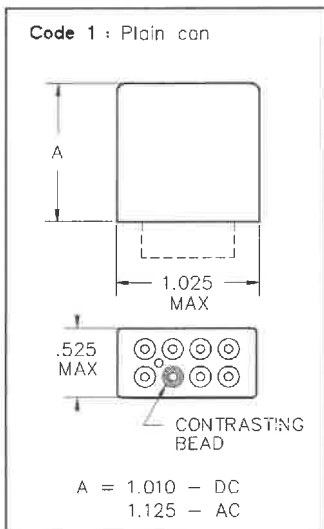

GENERAL NOTES

- Unless otherwise specified, all tests made at nominal coil voltages, @ 25°C.
- For special coil variations, switching configurations, terminals styles and mounting types, consult the factory.
- Unless otherwise specified, tolerances on decimal dimensions are ± .010".
- Specifications contained herein are subject to change without notice.