

Miniature 10 Amps • 2PDT Magnetic Latching To MIL-PRF-83536

SPECIFICATIONS

GENERAL

Contact Arrangement.....2PDT (2 Form C)
Magnetic Latching

Weight.....1.4 oz approx.
Designed to meet the requirements of MIL-PRF-83536

PERFORMANCE

Contact Rating (Note 1):

Resistive..... 10 Amps @ 28 VDC or
115/208V 400 Hz

Inductive.....8 Amps @ 28 VDC or
115/208V 400 Hz
2.5 Amps @ 115/208V 60 Hz

Motor..... 4 Amps @ 28 VDC or
115/208V 400 Hz
2 Amps @ 115/208V 60 Hz

Lamp.....2 Amps @ 28 VDC or
115/208V 400 Hz
1.5 Amps @ 115/208V 60 Hz

Life 100,000 operations minimum @ rated
resistive load, 125°C

Latch/Reset Power500 mw approx.

Latch/Reset Time:

DC Coil **AC Coil**

10 ms max 20 ms max

Excluding bounce time at nominal coil voltage

Contact Bounce Time..... 1 ms max
@ rated contact load, 28 VDC

Contact Voltage Drop:

Before Life 100 mv max @ 10 Amps
and 6 VDC

After Life 125 mv max @ 10 Amps
and 6 VDC

ENVIRONMENTAL

Temperature Range..... -70°C to +125°C

Vibration (Note 2).....0.12" DA 10 - 70 Hz
30 G's 70 - 3,000 Hz

Shock (Operating)(Note 2)200 G's 6 ms

ELECTRICAL CHARACTERISTICS

Duty Cycle..... Continuous

Insulation Resistance100 megohms
@ 500V 25°C

Dielectric Strength:

Sea Level:

Contact to Case 1,250 VRMS

Contact to Coil 1,250 VRMS

Coil to Case 1,000 VRMS

Across Open Contacts 1,250 VRMS

80,000 Feet:

All Points..... 350 VRMS

MIL-PRF-83536/12 QUALIFIED to ER level L

Notes:

- For other ratings consult the factory.
- For applications requiring higher shock and vibration, consult the factory.
- AC coil line frequency 50 to 400 Hz.

COIL DATA:

MODEL BR247 PART NUMBER	BR247-38(0)-6V	BR247-150(0)-12V	BR247-600(0)-28V	BR247-1550(0)-48V	BR247AC-(X)-115V (Note 3)
NOMINAL COIL VOLTAGE	6 VDC	12 VDC	28 VDC	48 VDC	115 VAC
MAXIMUM COIL VOLTAGE	8 VDC	15 VDC	29 VDC	59 VDC	122 VAC
LATCH/RESET VOLTAGE (MAX @ +125°C)	4.5 VDC	9 VDC	18 VDC	36 VDC	90 VAC
LATCH/RESET VOLTAGE (MAX)	3 VDC	6 VDC	13 VDC	24 VDC	72 VAC
COIL RESISTANCE ± 10% @ 25°C	38 OHMS	150 OHMS	600 OHMS	1550 OHMS	I = 0.04 AMPS

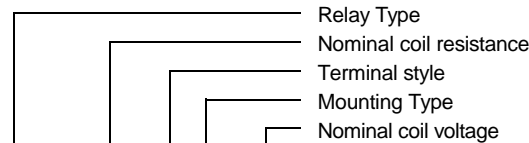

BR247 - 600 A 1 - 28V

SCHEMATIC

TERMINAL VIEW

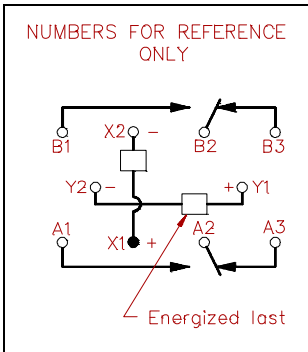

TERMINAL STYLES

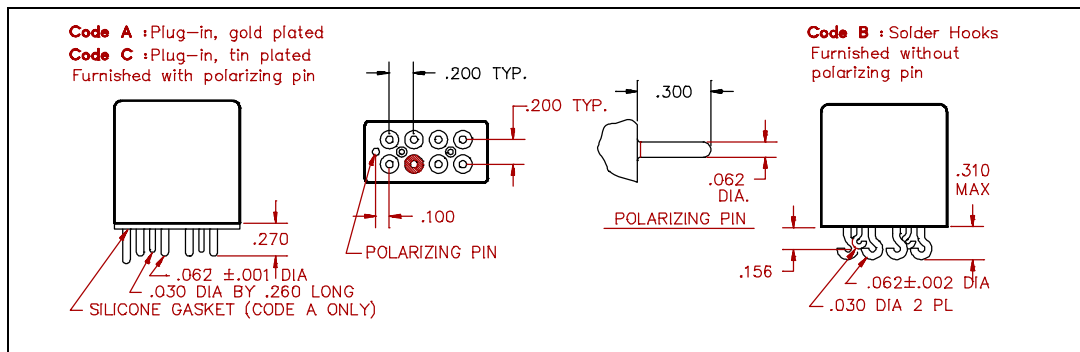

MOUNTING CODES

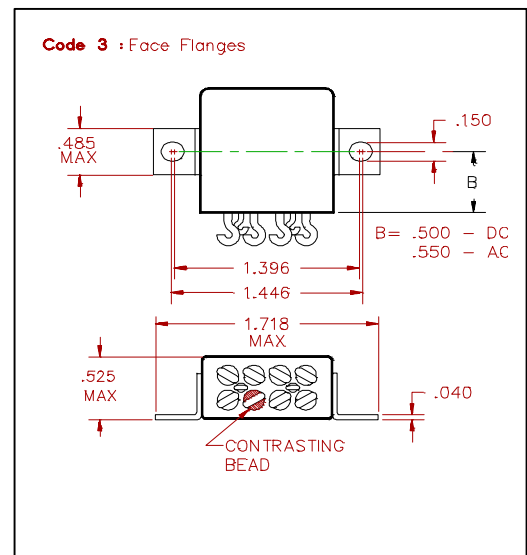
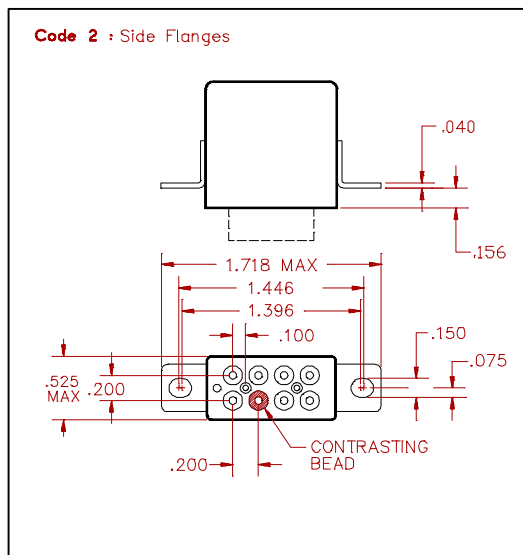
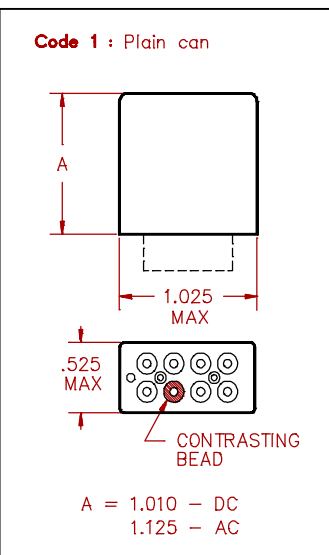

GENERAL NOTES

- Unless otherwise specified, all tests made at nominal coil voltages, @ 25°C.
- For special coil variations, switching configurations, terminals styles and mounting types, consult the factory.
- Unless otherwise specified, tolerances on decimal dimensions are ± .010".
- Specifications contained herein are subject to change without notice.