

4

3

2

1

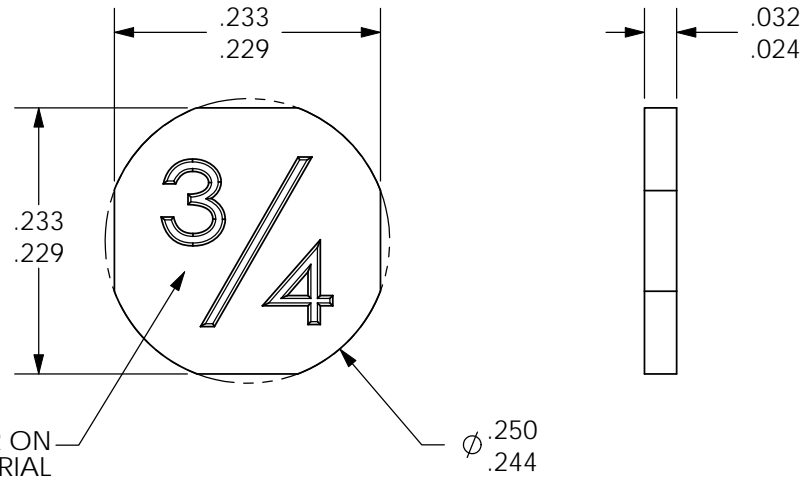

STAMP CHARACTER ON SMOOTH SIDE OF MATERIAL

NOTES:

- 1. ALL CHARACTERS MUST BE HOT STAMPED TO A DEPTH OF .001 MINIMUM.
2. CHARACTER SPECIFICATIONS: WITH THE EXCEPTION NOTED \* ALL CHARACTERS SHALL BE "GOTHIC" TYPESET STYLE.
3. WHITE COLOR HOT STAMP FOIL TO BE API FOILS INC. PEC - 5100 OR EQUIVALENT.
4. CHARACTER STAMPING MUST MEET SPEC. 12506 - 56.
5. CHARACTERS TO BE PARALLEL TO INSERT TO WITHIN +/- 5 degrees.
6. CODE SHOULD BE CENTERED WITHIN +/- .005 OF INSERT CENTERLINE IN THE VERTICAL AND HORIZONTAL POSITION.
7. FOR 3SB DEVICE ONLY, ANY DASH NUMBER CAN BE MADE BY STAMPING A BLANK INSERT WITH THE DESIRED AMP RATING USING WHITE INK.
8. CERTIFICATION OF CONFORMANCE REQUIRED.

Table with 3 columns: NAME, DRAWING SYMBOL, AIAG QS9000 DEFINITION. Rows include CRITICAL, SIGNIFICANT, and SPC.

Revision table with columns: ZONE, REV., REVISION DESCRIPTION, ECN NO., DATE. Row 1: U, NOTE 2; GOTHIC TYPESET WAS HOLDEN & REMOVED COMPANY REF.: D.P., ECO-059379, 15-OCT-2010

Table with 3 columns: PART NO., RATING NO., MATERIAL. Lists parts 27771-1 through 27771-28 with their respective ratings and materials (KYDEX T, COLOR # 32169 (GREEN)).

Part information block including: FOR REFERENCE ONLY, CHECK LATEST REVISION BEFORE USE. PARTS MADE TO THIS PRINT MUST CONFORM TO E9898 REV. E. Sensata Technologies logo and address, title 'INSERT (RATING)', size 'B', drawing number '27771', revision 'U', scale '6:1', and sheet '1 OF 1'.

4

3

2

1

DEVICE: PROJECT: