

Property of
Sensata Technologies

ZONE	REV.	REVISION DESCRIPTION	ECN NO.	DATE
B3	F	ADD 25 AMP CHARACTERISTICS; PART LABEL WAS T.I. DATE CODE WAS CUSTOMER PN; PD	ECN0050701	20-APR-2009

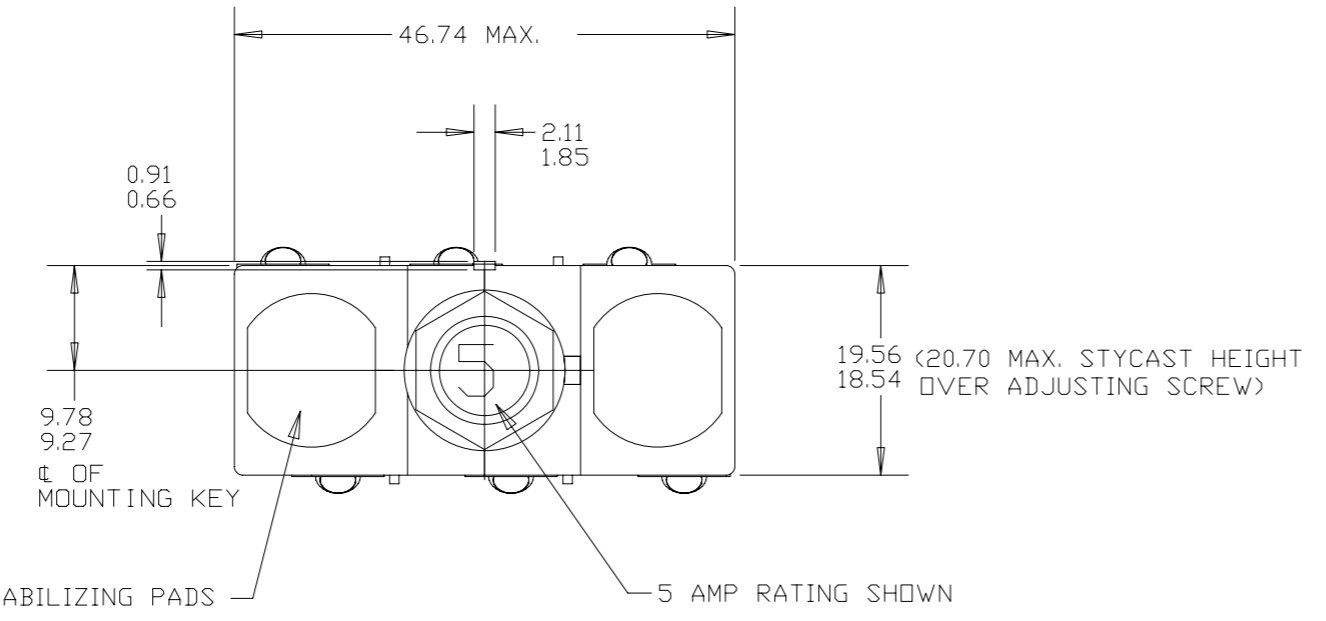

PERFORMANCE CHARACTERISTICS

DETAIL PERFORMANCE PER MIL-C-5809

OVERLOAD CYCLING	-----	100 CYCLES AT 200% RATING
VIBRATION	-----	CURVE "J" OF EUROCAE ED-14B 3G'S, 2000HZ
MECHANICAL SHOCK	-----	50 G'S
ACCELERATION	-----	10 G'S
SAND AND DUST	-----	12 HOURS
CORROSION	-----	SALT SPRAY 50 HOURS
HUMIDITY	-----	10 DAYS
EXPLOSION PROOF	-----	WHILE INTERRUPTING RUPTURE CURRENTS

ENDURANCE:

	120 VAC	400 HZ INDUCTIVE	400 HZ RESISTIVE	2500 CYCLES	5000 CYCLES	5000 CYCLES
MECHANICAL			NO LOAD			

SINGLE * OR THREE PHASE CALIBRATION: 3 AMP THRU 25 AMP

	MIN. ULT. TRIP	MAX. ULT. TRIP	200%	500%	1000%
+25°C, +77°F	110% RATING	145% RATING	4-20 SEC.	.40-2.0 SEC.	.10-.53 SEC.
-54°C, -65°F	110% RATING	165% RATING	6-40 SEC.	.55-3.5 SEC.	.15-.80 SEC.
+71°C, +160°F	100% RATING	145% RATING	3-20 SEC.	.33-1.7 SEC.	.08-.40 SEC.

RUPTURE: 3 AMP THRU 25 AMP 120 VAC, 400 HZ 65 In AMPS (RMS)

MAXIMUM OPERATING FORCES

PULL OUT	-----	12 LBS. MAX. (53.4 N)
RESET	-----	12 LBS. MAX. (53.4 N)

OPERATING ALTITUDE: 72,200 FT. (22,000 M)

WEIGHT: 65.0 GRAMS MAX. (.143 LBS.)

VOLTAGE DRDP:

3 AMP	-----	0.40 VOLTS MAX.
5 AMP	-----	0.35 VOLTS MAX.
7.5 AMP	-----	.192 VOLTS MAX.
10 AMP	-----	.176 VOLTS MAX.
15 AMP	-----	.176 VOLTS MAX.
20 AMP	-----	.176 VOLTS MAX.
25 AMP	-----	.176 VOLTS MAX.

* SINGLE PHASE MAXIMUM ULTIMATE TRIP VALUES APPLY WITH OTHER TWO PHASES CARRYING 100% OF RATED CURRENT

NOTES:

1. EPOXY SURFACES ARE NON-DIMENSIONED, ENVELOPE DRAWING DIMENSIONS DO NOT APPLY TO THESE PROJECTED EPOXY SURFACES.
2. TERMINAL AND MOUNTING HARDWARE MAY BE PACKAGED RATHER THAN INSTALLED.
3. COUNTRY OF ORIGIN IS SHOWN FOR ILLUSTRATION PURPOSES ONLY. COUNTRY OF ORGIN TO BE IDENTIFIED AS REQUIRED.
4. DATE CODE PER 10588-285.
5. ALL MARKINGS TO BE MADE IN APPROXIMATE POSITIONS SHOWN WITH BLACK INK PER 12506-70, 2MM HIGH CHARACTERS.

D

D

C

C

B

B

A

A

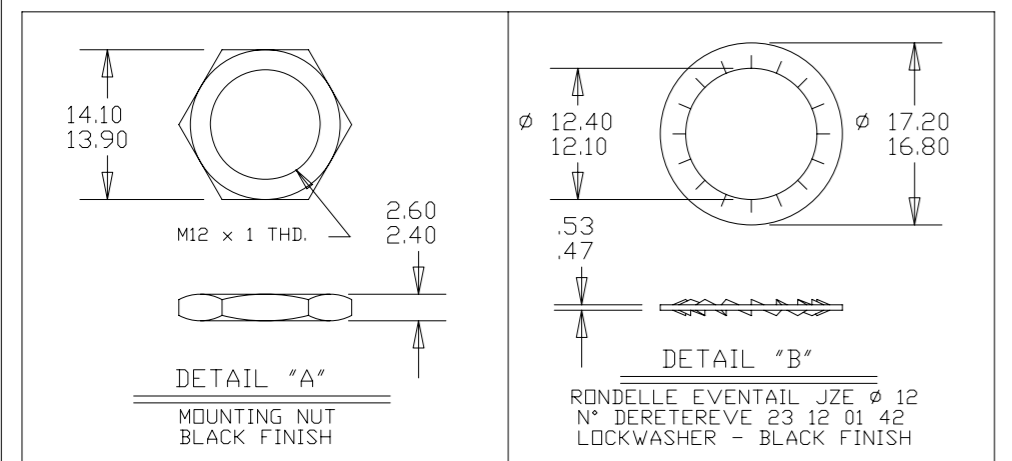
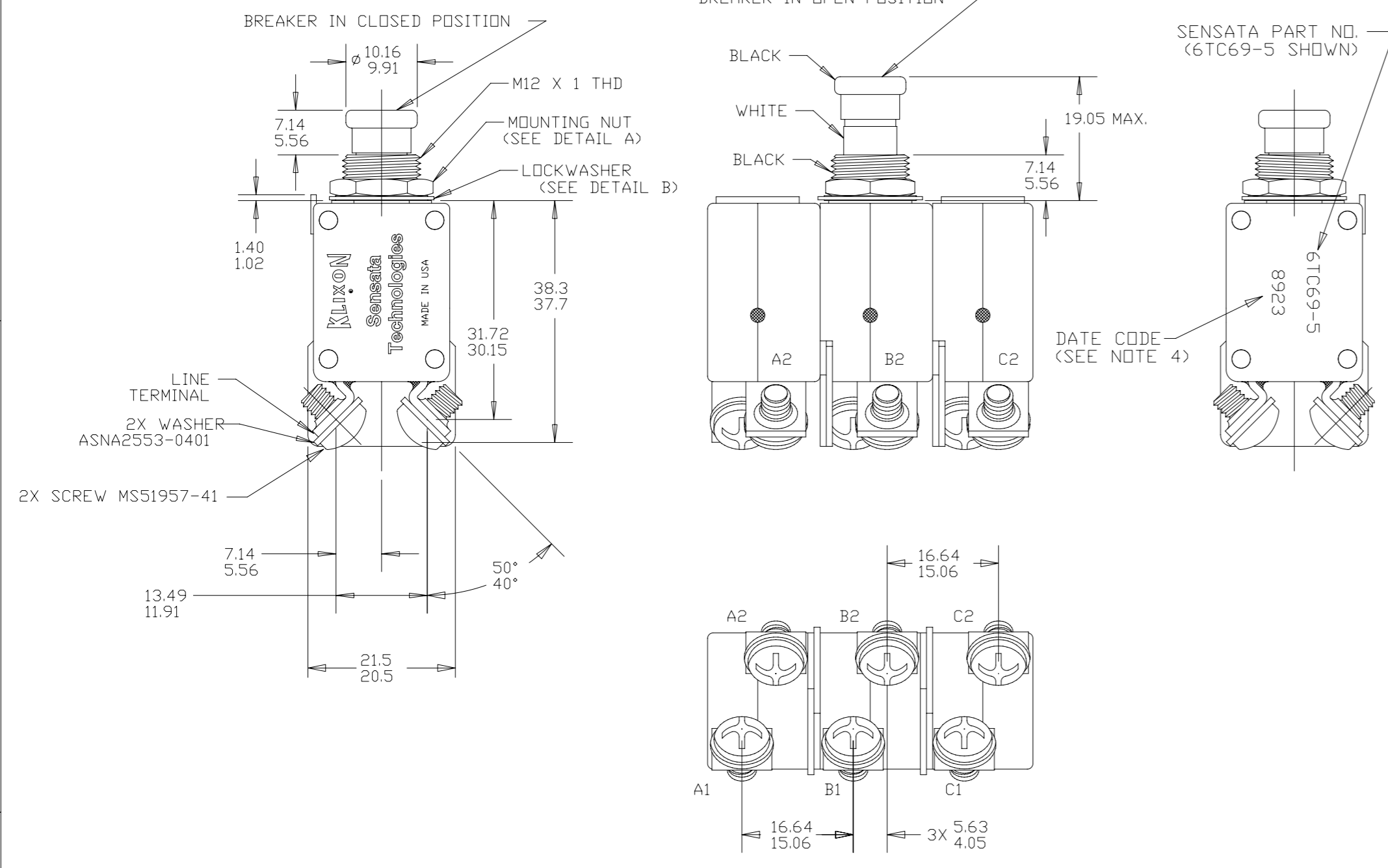

FOR REFERENCE ONLY, CHECK LATEST REVISION BEFORE USE. PARTS MADE TO THIS PRINT MUST CONFORM TO E9898 REV. E		 529 PLEASANT STREET P.O. BOX 2964 ATTLEBORO, MA 02703	
DRAWN JOSE GONZALEZ DATE 05-OCT-2000 ENGINEER E. QUINTEROS DATE 05-OCT-2000 APPROVED P. FOLEY DATE 05-OCT-2000 APPROVED P. BERG DATE 05-OCT-2000	SENSATA TECHNOLOGIES PROPRIETARY AND CONFIDENTIAL. NEITHER THIS PRINT NOR THE INFORMATION CONTAINED HEREON IS TO BE USED AGAINST THE INTERESTS OF SENSATA TECHNOLOGIES OR AGAINST THE INTERESTS OF ANY OF ITS AFFILIATED COMPANIES OR WHOLLY OWNED SUBSIDIARIES.		TITLE AMBIENT COMPENSATED CIRCUIT BREAKER PUSH-PULL, TRIP FREE ENVELOPE DRAWING
DO NOT SCALE DRAWING THIRD ANGLE PROJECTION	SIZE A2 SCALE 4:1 AUTOCAD	DWG NO. 6TTC69 SHEET 1 OF 1	REV. F

DEVICE: PROJECT: 1

4

3

2

1

4

3

2

1