

Property of  
Sensata Technologies

| ZONE | REV. | REVISION DESCRIPTION       | ECN NO.    | DATE        |
|------|------|----------------------------|------------|-------------|
| D4   | R    | .780 MAX WAS .781/.719; PD | ECO-111344 | 25-FEB-2015 |

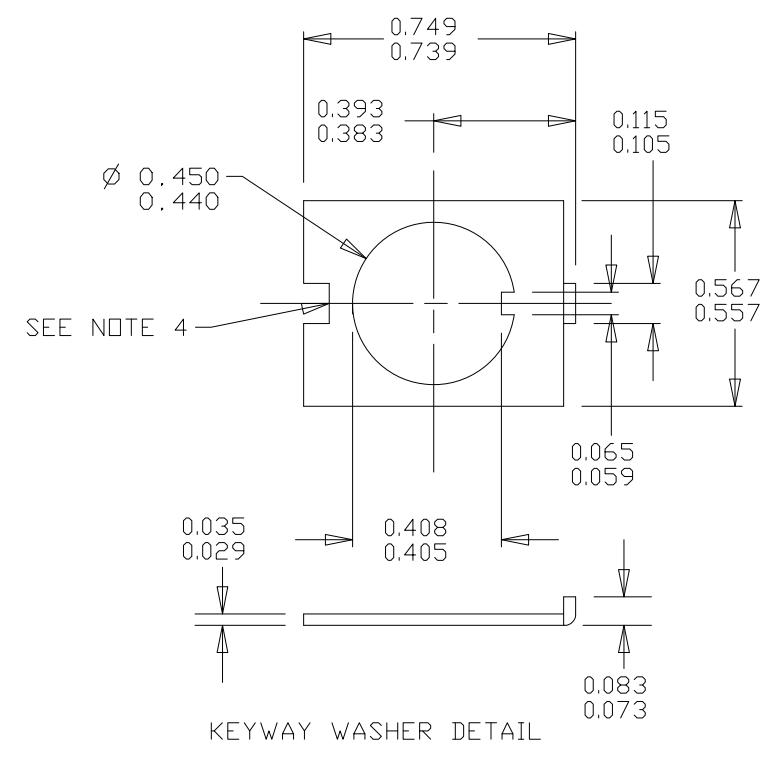
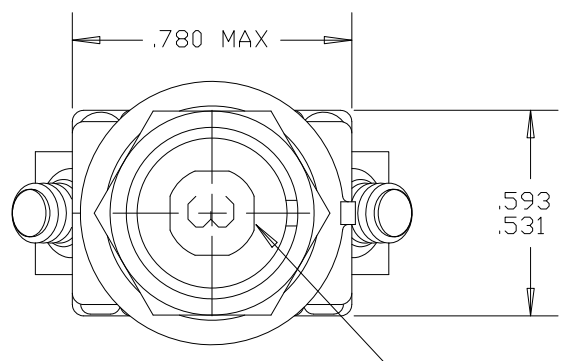

PERFORMANCE CHARACTERISTICS (DETAIL PERFORMANCE PER MIL-C-5809)

OVERLOAD CYCLING ----- 100 CYCLES AT 200% RATING  
 SINUSOIDAL VIBRATION ----- 10 G'S MINIMUM 50-500 HZ  
 CORROSION ----- SALT SPRAY 48 HOURS  
 ACCELERATION ----- 10 G'S MINIMUM  
 SAND AND DUST ----- 12 HOURS  
 CORROSION ----- SALT SPRAY 50 HOURS  
 HUMIDITY ----- 10 DAYS  
 EXPLOSION PROOF ----- WHILE INTERRUPTING RUPTURE CURRENTS

MAXIMUM OPERATING ALTITUDE: 80,000 FT. (24,384 M)

WEIGHT: 30.0 GRAMS MAX.

MAXIMUM OPERATING FORCES:  
 PULL OUT ----- 5 LBS. MAX. (222 N)  
 RESET ----- 5 LBS. MAX. (222 N)

ENDURANCE:  
 120 VAC ----- 400 HZ RESISTIVE ----- 5000 CYCLES  
 120 VAC ----- 400 HZ RESISTIVE ----- 5000 CYCLES  
 30 VDC ----- INDUCTIVE ----- 2500 CYCLES  
 30 VDC ----- RESISTIVE ----- 5000 CYCLES  
 NO LOAD ----- MECHANICAL ----- 5000 CYCLES

CALIBRATION:

| AMBIENT TEMP.  | HOLD        | TRIP        | 200%      | 500%         | 1000%         |
|----------------|-------------|-------------|-----------|--------------|---------------|
| +25°C (+77°F)  | 115% RATING | 150% RATING | 2-20 SEC. | .16-1.0 SEC. | .046-.28 SEC. |
| -55°C (-67°F)  | 135% RATING | 180% RATING | -----     | -----        | -----         |
| +71°C (+160°F) | 90% RATING  | 130% RATING | -----     | -----        | -----         |

| PART NO.      | AMP RATING | MAXIMUM VOLTAGE DROP | CURRENT INTERRUPTING CAPACITY |           |
|---------------|------------|----------------------|-------------------------------|-----------|
|               |            |                      | 120 VAC, 400 HZ               | 28 VDC    |
| 7274-44-1/2   | 1/2        | 2.00                 | UNLIMITED                     | UNLIMITED |
| 7274-44-1     | 1          | 1.10                 | UNLIMITED                     | UNLIMITED |
| 7274-44-1 1/2 | 1 1/2      | 0.75                 | UNLIMITED                     | UNLIMITED |
| 7274-44-2     | 2          | 0.70                 | UNLIMITED                     | UNLIMITED |
| 7274-44-3     | 3          | 0.33                 | UNLIMITED                     | UNLIMITED |

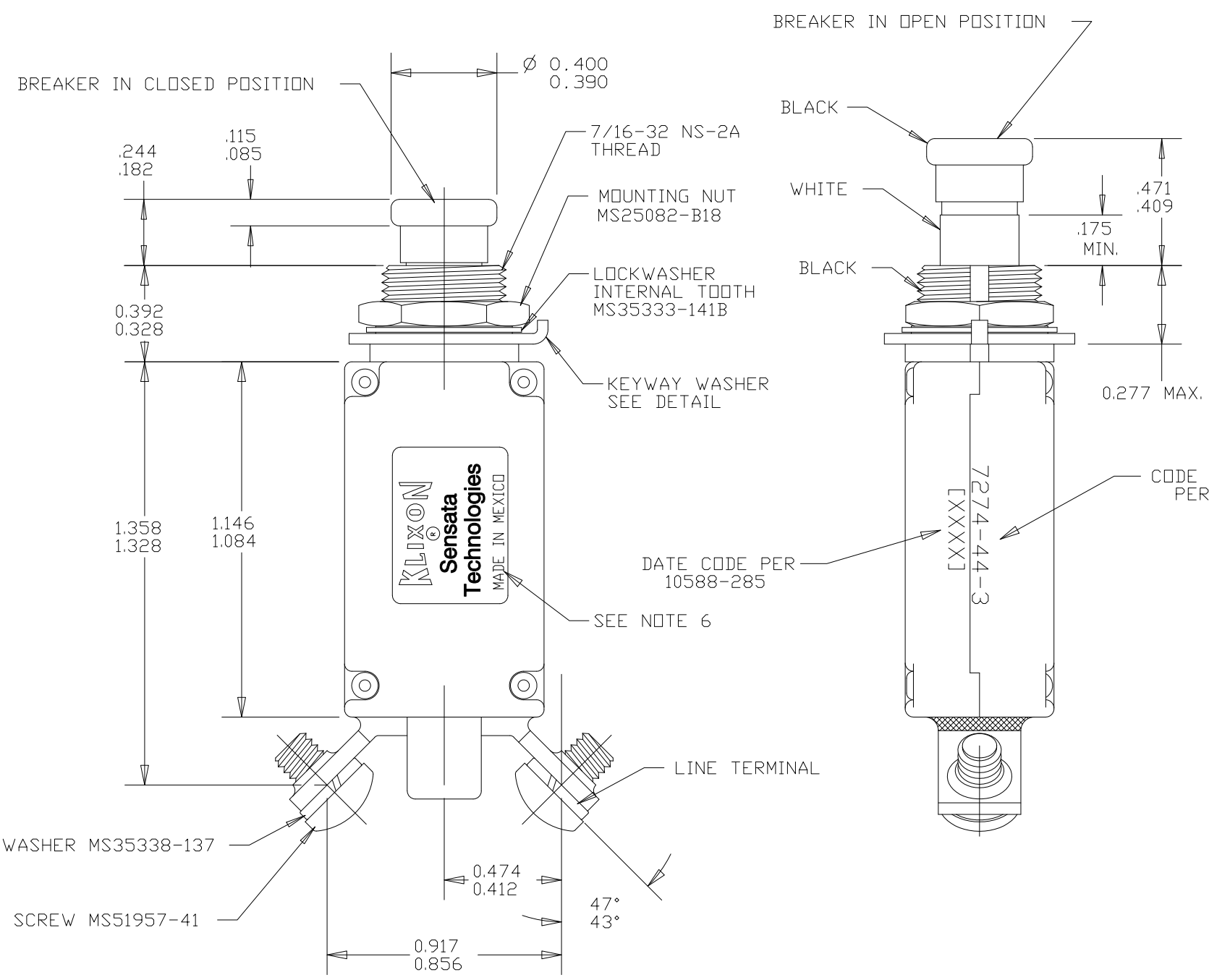

- NOTES:
- ALL MOUNTING HARDWARE HAS A DULL BLACK FINISH.
  - CIRCUIT BREAKERS ARE SUITABLE FOR MOUNTING IN A 1/8" THICK PANEL OR LESS.
  - EPOXY SURFACES ARE NON-DIMENSIONED, ENVELOPE DIMENSIONS DO NOT APPLY TO THESE PROJECTED EPOXY SURFACES.
  - NON FUNCTIONAL NOTCH ON THE BACK OF THE KEYWAY WASHER IS OPTIONAL.
  - TERMINAL AND MOUNTING HARDWARE MAY BE PACKAGED RATHER THAN INSTALLED.
  - COUNTRY OF ORIGIN IS SHOWN FOR ILLUSTRATION PURPOSES ONLY. COUNTRY OF ORIGIN TO BE IDENTIFIED AS REQUIRED.

FOR REFERENCE ONLY, CHECK LATEST REVISION BEFORE USE. PARTS MADE TO THIS PRINT MUST CONFORM TO E9898 REV. E

|   |   |   |
|---|---|---|
| DRAWN<br><b>J.D. MAYALL</b><br>DATE 17-JAN-1995<br>ENGINEER<br><b>K.B. GASSER</b><br>DATE 17-JAN-1995<br>APPROVED<br><b>D.R. PETRIE</b><br>DATE 17-JAN-1995<br>APPROVED<br>DATE | SENSATA TECHNOLOGIES PROPRIETARY AND CONFIDENTIAL. NEITHER THIS PRINT NOR THE INFORMATION CONTAINED HEREON IS TO BE USED AGAINST THE INTERESTS OF SENSATA TECHNOLOGIES OR AGAINST THE INTERESTS OF ANY OF ITS AFFILIATED COMPANIES OR WHOLLY OWNED SUBSIDIARIES.<br>UNLESS OTHERWISE SPECIFIED DIMENSIONS ARE IN INCHES<br>TOLERANCES<br>DECIMALS      ANGLES | <br>529 PLEASANT STREET<br>P.O. BOX 2964<br>ATTLEBORO, MA 02703<br>TITLE<br><b>7274-44 STYLE CIRCUIT BREAKER<br/>         PUSH-PULL, TRIP FREE<br/>         ENVELOPE DRAWING</b><br>SIZE    DWG NO.    REV.<br><b>C      7274-44      R</b><br>SCALE 1:1    AUTOCAD    SHEET 1 OF 1 |
|---|---|---|

DO NOT SCALE DRAWING    THIRD ANGLE PROJECTION    DEVICE: PROJECT:3457 1